

Concrete
Forming Systems

Bridge Deck Forming and
Hanging Systems

Reinforcing
Bar Supports

Concrete
Anchoring Systems

Rock Anchoring
and Bolt Systems



ACROW-RICHMOND

THE HIDDEN STRENGTH™

LA FORCE CACHÉE

PRECAST CONCRETE PRODUCTS

LIFTING
CONNECTING
FORMING
ACCESSORIES
CHEMICALS



Table of Contents

LIFTING	
COIL LIFTING INSERTS	
	LP - 2 Lifting Inserts.....6
	LP - 4 Lifting Inserts.....6
	Lifting Inserts (LI-4) and (LI-6).....7
	Lifting Handle Tyloop (LTLH).....7
	Type L.....8
	Type EC-2.....9
	Type EC-4.....9
	Type EC-6.....10
	Lifting Tyscru (LT2) and (LT 4).....11
	Lift Lags (LLAG).....12
SURFACE LIFT	
	Quick Pin.....13
	Quick Pin with Lifting Eye.....13
	Double Head Quick Pin.....14
	Utility V-Anchor.....14
	U-Anchor.....15
	Plate Anchor.....15
	Two Hole Anchor.....16
	Panel Pick Anchor.....16
	T-Bar Anchor.....16
	Wire Rope.....17
	Wire Loop with Eye Bolt.....17
	Threaded Wire Ropes.....18
	Wavy Tail Anchor.....18
EDGE LIFT	
	Erection Anchor.....19
	Erection Anchor with Shear Plate.....19
	Forged Erection Anchor.....19
	Forged Erection Anchor with Shear Plate.....20
	Sandwich Panel Erection Anchor.....20
	Sandwich Panel Erection Anchor with Shear Plate.....20
LIFTING DEVICES	
	Lifting Bracket (LB).....21
	Heavy Duty Swivel / Pivot Lift Plate (LDLP).....21
	Type K Lifting Eye.....22
	Lifting Eye Bolt.....22
	Quick Pin Clutch.....23
	Ring Clutch.....23
	Quick Pin Chain Clutch.....24
VOID FORMERS	
	Quick Pin Void Former.....25
	Utility Void Former.....25
	Plate Anchor Void Former.....25
	U-Anchor Void Former.....26
	Double Head Quick Pin Void Former.....26
	Holding Plate for Plate Anchor Void Former.....26
CONNECTING	
FERRULE CONCRETE INSERTS	
	LF & LFW.....28
	ECF-2 & ECF-2W.....29
	ECF-4 & ECF-4W.....29
	ECF-6 & ECF-6W.....29
	LP-2F Connecting Inserts.....30
	LP-4 Connecting Inserts.....30

Table of Contents

	Loop Insert (SLF).....31		Multiform Type 2.....45
	Ferrule Diaphragm Loop (PFDL) & Re-bar Connector (PDR).....31		Precast Angle Hanger.....46
	Hair Pin Type Inserts.....32	ACCESSORIES	
	AR Thru-Insert (RT 134).....33	CONTINUOUS THREADED LAGSTUD	
	Thin Slab Ferrule Insert (ITBF & ITSF).....34		Continuous Threaded Lagstud.....48
	Plain Ferrule Insert (IPF & IPFW).....35	LAG THREAD	
	NC Zinc Precast Threaded Insert.....35		Lagstud Bolt.....50
PRECAST ACCESSORIES			Lagnut.....50
	Askew Head Bolts.....36		Handle Lagnut.....51
	Peerless Wedge Insert.....36		Wingnut.....51
	Lintel Anchor Wedge Insert.....36	STRAND DEFLECTION INSERT	
	Continuous Slotted Insert.....37		Single Line Strand Deflection Insert with Rollers (SPD).....52
	Turnbuckle.....37		Strand Deflection Insert with Rollers.....52
	Formsavers™.....38	PLUGS & SPACERS	
FORMING			Plastic Setting Plugs.....53
PRECAST FORMING ACCESSORIES			Plastic Coil Setting Plug.....53
	Standard 2-Strut Tyloop (TL2).....40		Polyserts - Plastic Fixing Blocks.....53
	Heavy 2-Strut Tyloop (TL2-H).....40		Bubble Spacers.....54
	Flared 2-Strut Tyloop (TL2F).....40		Manhole Steps.....54
	Standard 4-Strut Tyloop (TL4).....41	REBAR SUPPORT	
	Heavy 4-Strut Offset Flared Tyloop (TL4-H).....41		(SB) Slab Bolster.....55
	Heavy Hex Rod Coupler.....42		(PSB) Slab Bolster And All Plastic Continuous High Chair.....55
	Lag Thread Coupler.....42		(CHC) Continuous High Chair.....55
	Flat Washer.....43		Tie Wire.....55
	Magfly "AP" Magnet.....44		Stencil Cutting Machine.....56
	Magnet GB.....44		Stencil Materials and Accessories.....56
	Multiform Bracket.....44		Linden Chairs.....57
	Multiformwork Inside Corner H.....44		Plastic Clip on Chairs.....58

Table of Contents

	Reinforcing Bar X-Chair.....58		Fasteners.....66
	Precast Chair.....58	FORMING ACCESSORIES	
	Smooth Edge Wagon Wheel.....59		Form Liners.....67
	Ribbed Edge Wagon Wheel.....59		Formwork Pry Bar.....67
	Spun Cast Wheel.....59		Reglet.....67
	Stack Hi-Chairs.....60		Sill Gaskets / Ethafoam.....67
	EA Chair.....60	SAFETY PRODUCTS	
	Recess Plug.....60		Safety Products.....68
	Prestress Sheathing.....60	CHEMICALS	
	Chain Guards.....60	FORM RELEASE	
INSTALLATION ACCESSORIES			Rich-Cote Form Release - W.B. - Summer Grade.....70
	Horseshoe Shims.....61		Rich-Cote Form Release - W.B. - Winter Grade.....70
	Econo Shims.....61		Form Release Agents.....70
	Fluted Plastic Shims.....61	SEALERS	
PRECAST ACCESSORIES			Premium High Gloss Acrylic Sealer.....71
	Plain Economy Plastic Shims (EPPS).....62		Premium Acrylic Sealer.....71
	Expanded Mesh.....62		High Gloss Acrylic Sealer.....71
	Form Sealant.....62		Acrylic Sealer.....71
CHAMFERS		ADHESIVES & OTHER COMPOUNDS	
	Chamfer Strips.....63		Adhesives.....72
	PVC - Chamfer Strips - Architectural Reveal Series.....64		Bonding Agents.....72
	PVC - Chamfer Strips - Rustication.....64		Colour Pigments.....72
	PVC - Single Chamfer.....65		Patching Repair Products.....72
	PVC - Double Chamfer.....65		Concrete Curing Compounds.....73
	PVC - Concrete Accessories.....65		Epoxy Anchoring.....73
FASTENING ACCESSORIES		GENERAL INFORMATION.....74	
	Dovetail Brick Anchors.....66		
	Dovetail Anchor Slot.....66		

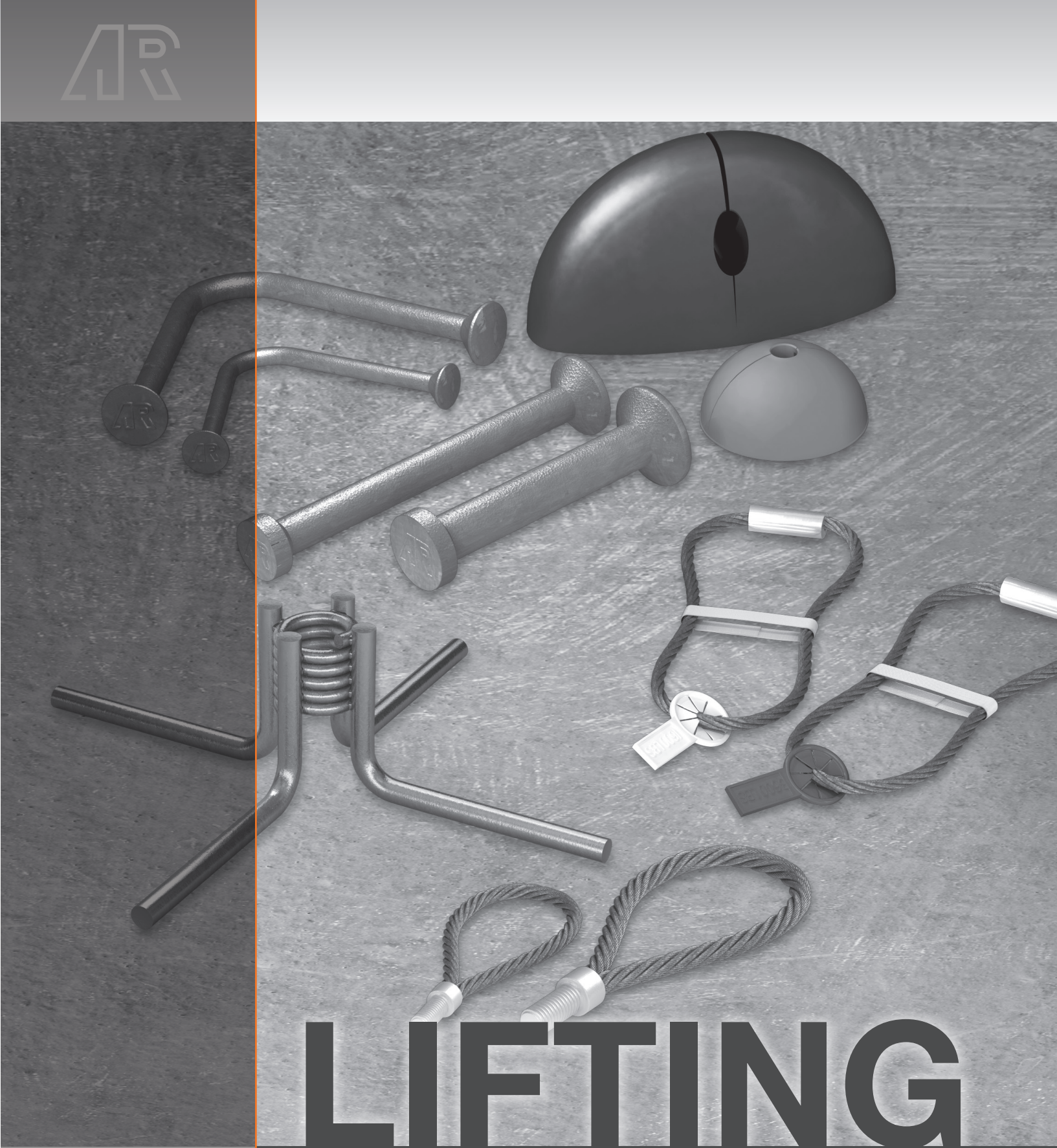

LIFTING

Coil Lifting Inserts

AR manufactures concrete inserts with National Coarse (NC) and lag type threads for use in structural connections and/or permanent connections. All AR lag products can be used for either type of connection, National Coarse (NC) products are more common for permanent connections application where as lag type products are more commonly used for lifting application.

LP - 2 Lifting Inserts

The AR LP-2 Lifting Insert is manufactured with 1/2" and 3/4" (13 mm and 20 mm) diameter coils to engage AR lag thread lifting bolts. Open or closed ferrules LP - 2F for use with 1/2" (M12), 5/8" (M16) and 3/4" (M20) diameter machine bolts are available as a connecting device or for special lifting conditions. Recommended for use in thin flat slabs where a high strength insert is not required.

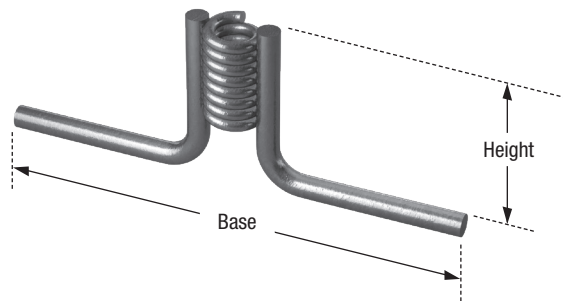

4:1 Approximate Safety Factor

BOLT DIAMETER inch (mm) COIL	BASE inch (mm)	INSERT HEIGHT inch (mm)	MIN. CONC. THICKNESS inch (mm)	WORKING LOAD lbs (kN)	
				TENSION	SHEAR
1/2 (12)	4 3/4 (120)	2 1/2 (65)	3 (75)	900 (4.00)	1,610 (7.10)
1/2 (12)	(120)	2 1/2 (65)	3 (75)	940 (4.10)	2,700 (12.00)
3/4 (20)	7 (180)	3 1/2 (90)	4 (100)	2,000 (8.90)	2,850 (12.60)

20 MPa (3,000 psi) concrete. Working loads shown based on 230 mm (9") edge distance.

LP - 4 Lifting Inserts

The AR LP-4 Lifting Insert is manufactured with 3/4", 1", 1 1/4", and 1 1/2" (20, 25, 32, and 38 mm) diameter coils to engage AR lag thread lifting bolts. Open or closed ferrules LP - 4F for use with 3/4", 1", and 1 1/4" (20, 25, and 32 mm) size machine bolts are available as a connecting device or for special lifting conditions.

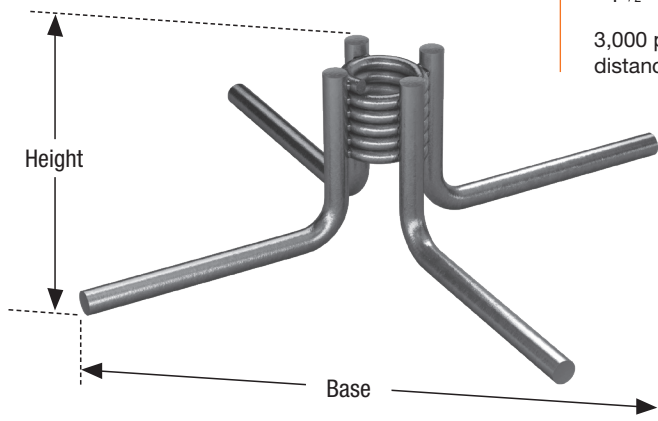

4:1 Approximate Safety Factor

BOLT DIAMETER inch (mm) COIL	BASE inch (mm)	INSERT HEIGHT inch (mm)	MIN. CONC. THICKNESS inch (mm)	WORKING LOAD lbs (kN)	
				TENSION	SHEAR
3/4 (20)	7 7/8 (200)	3 1/2 (90)	4 (100)	3,000 (13.3)	2,850 (12.6)
1 (25)	9 (230)	5 1/2 (140)	6 (150)	7,130 (31.7)	3,750 (16.6)
1 1/4 (32)	9 1/2 (240)	5 1/2 (140)	6 (150)	7,130 (31.7)	3,750 (16.6)
1 1/2 (38)	9 1/2 (240)	7 1/2 (190)	8 (200)	10,100 (44.8)	7,500 (33.3)

3,000 psi (20 MPa) concrete. Working loads shown based on 9" (230 mm) edge distance.

LI - 4 & LI - 6 Lifting Inserts

AR LI-4 and LI-6 inserts are used for handling, erection, bracing connections with the additional advantages of being available in any height and allowing less interference with reinforcing steel. The LI-4 type and LI-6 type are furnished with stainless steel feet. To order, provide diameter, height (usually 1/2" (13 mm) less than structural concrete panel thickness), and type by symbol and name.

4:1 Approximate Safety Factor

FACE LIFTING INSERTS SIZE AND TYPE inch (mm)	Min. Panel Thickness inch (mm)	Insert Height inch (mm)	RECOMMENDED WORKING LOADS*	
			Concrete Strength at Time of Lifting	
			20.0 Mpa (3000 psi)	
			Tension lbs. (kN)	Shear lbs. (kN)
3/4 (20) LI-4	4 (100)	3 1/2 (90)	2,500 (11.20)	2,000 (8.90)
1 (25) LI-4	6 (150)	5 1/2 (140)	6,500 (28.93)	4,500 (20.00)
1 1/4 (32) LI-4	6 (150)	5 1/2 (140)	6,500 (28.93)	4,500 (20.00)
1 1/2 (38) LI-6	8 (200)	7 1/2 (190)	12,500 (55.70)	7,000 (31.20)

Recommended design load = dead load + 50% for impact. Safe working loads may in some cases be modified when the concrete compressive strength is other than shown above.

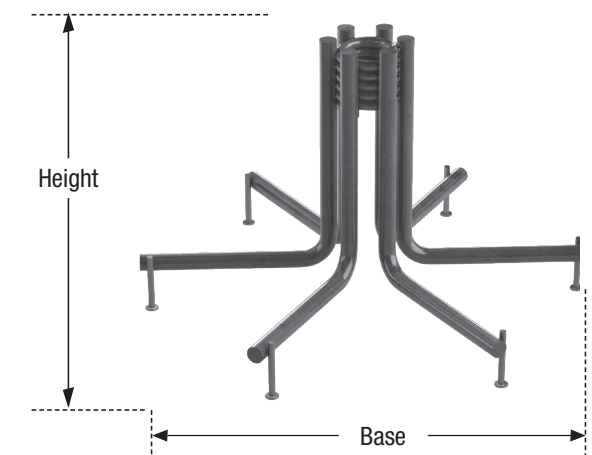
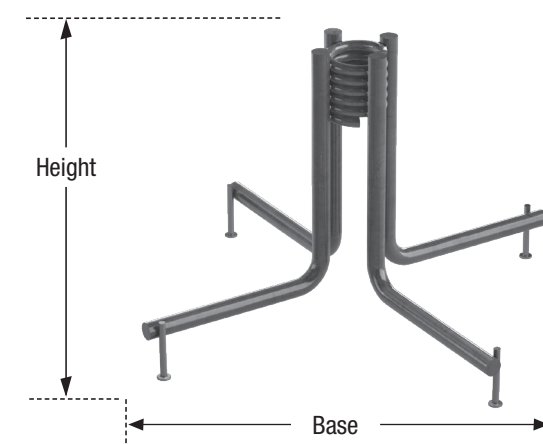

Lifting Handle Tyloop (LTLH)

The AR Lifting Handle Tyloop is designed for use in thin slabs. It is manufactured with 1/2", 3/4" and 1" (13 mm, 20 mm and 25 mm) diameter coils to engage AR lag thread lifting bolts. When embedded deeply in high strength concrete this insert offers substantial tensile load capacities. To order: provide diameter, symbol and name.

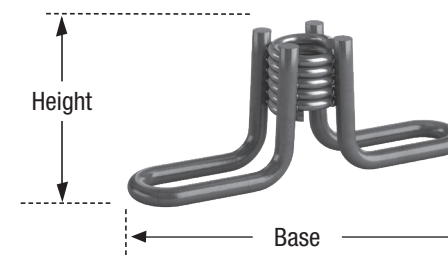

4:1 Approximate Safety Factor

BOLT DIAMETER inch (mm)	LENGTH inch (mm)	INSERT MINIMUM HEIGHT inch (mm)	WORKING LOADS*	
			Tension lbs. (kN)	Shear lbs. (kN)
1/2 (13)	5 (125)	1 3/4 (45)	1,125 (5)	1,610 (7.1)
3/4 (20)	5 1/2 (138)	2 (50)	1,500 (6.7)	2,700 (12)
1 (25)	6 (150)	2 1/2 (65)	1,500 (6.7)	2,850 (12.7)

3,000 psi (20 MPa) concrete. Working loads shown are based on 9" edge distance and 3" concrete thickness.

Structural Connection & Lifting Inserts

AR Structural Connection Inserts are prefabricated from a special design which distributes the bolt stresses into the concrete for greater strength. AR Structural Connection Inserts Type L, EC-2, EC-4 and EC-6 are furnished with coils to engage the AR lag thread bolts or rod, in sizes (1/2"), (3/4"), (1") and (1 1/2"). These inserts can also be supplied with special coils internally tapped to receive thread bolts in these sizes, and are also furnished with closed ferrules instead of coils, identified by "F", i.e. LF, ECF-2. Open ferrules are supplied on order. All inserts can be supplied with a Flat Washer Base for nailing the insert to the sheathing or decking of the form, and are identified by the letter "W". i.e. LFW, ECF-2W. Tapped Coil Type Inserts should not be used for lifting purposes or when dynamic loads are present. Inserts are supplied plain, or plated for corrosion resistance. Protective plating or stainless steel material is available on request.

FINAL ANCHORAGE DETAIL

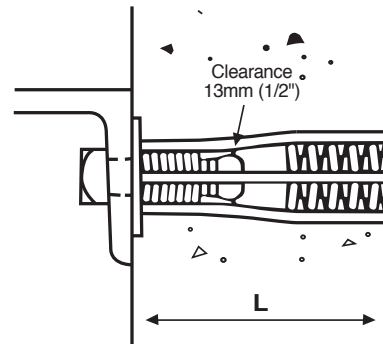

Type L



INSERT TYPE	DIA.	LENGTH inch (mm)	WIDTH inch (mm)	WASHER THICKNESS inch (mm)	WORKING LOAD lbs (kN)	
					SHEAR	TENSION
L	(3/8")	4 1/4" (102)	2 1/2" (60)	3/32" (2.38)	1,280 lbs. (5.7)	1,500 lbs. (6.65)
L	(1/2")	4 1/4" (102)	2 1/2" (60)	3/32" (2.38)	1,500 lbs. (6.65)	1,500 lbs. (6.65)
L	(3/4")	4 3/4" (115)	3" (70)	3/32" (2.38)	3,525 lbs. (15.65)	3,375 lbs. (15.00)

4:1 Approximate Safety Factor

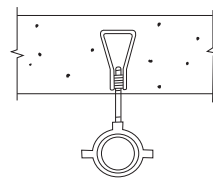

HANGING UTILITIES

BOLT DIAMETER AND SYMBOL	MIN. CONC. THICKNESS inch (mm)	INSERT LENGTH inch (L-mm)	INSERT WIDTH inch (O-mm)	WASHER THICKNESS inch (T-mm)	WORKING LOAD lbs (kN)	
					SHEAR	TENSION
3/8" Type L	6" (150)	4 1/4" (108)	2 1/2" (60)	3/32" (2.38)	1,280 lbs. (5.7)	1,500 lbs. (6.65)
1/2" Type L	6" (150)	4 3/4" (100)	2 1/2" (60)	3/32" (2.38)	1,500 lbs. (6.65)	1,500 lbs. (6.65)
3/4" Type L	6" (150)	4 3/4" (121)	3" (70)	3/32" (2.38)	3,525 lbs. (15.65)	3,375 lbs. (15.00)

4:1 Approximate Safety Factor

SIZE AND TYPE	FORCE IN kN (lbs) FOR EDGE DISTANCE - CENTERLINE OF INSERT TO NEAREST EDGE															
	1 1/2" (40mm)		2" (50mm)		3" (75mm)		4" (100mm)		5" (125mm)		6" (150mm)		8" (200mm)		9" (225mm)	
	TENSION SHEAR	TENSION SHEAR	TENSION SHEAR	TENSION SHEAR	TENSION SHEAR	TENSION SHEAR	TENSION SHEAR	TENSION SHEAR	TENSION SHEAR	TENSION SHEAR	TENSION SHEAR	TENSION SHEAR	TENSION SHEAR	TENSION SHEAR	TENSION SHEAR	
1/2" Type L	525 (2.30)	300 (1.30)	1,050 (4.60)	525 (2.30)	1,500* (6.60*)	900 (4.00)	1,200 (5.30)	1,500* (6.60*)							1,500* (6.60*)	1,500* (6.60*)
3/4" Type L	750 (3.30)	375 (1.60)	1,500 (6.60)	600 (2.60)	2,250 (10.00)	975 (4.30)	3,000 (13.30)	1,350 (6.00)	3,375* (15.00)	2,250 (10.00)	3,525* (15.60*)				3,375* (15.00*)	3,525* (15.60*)

Type EC-2



INSERT TYPE	DIA.	LENGTH inch (mm)	WIDTH inch (mm)	WASHER THICKNESS inch (mm)
EC-2	(3/4")	4 3/4" (115)	2 1/4" (57)	1/8" (270)
EC-2	(1")	5 3/4" (140)	2 5/8" (67)	3/16" (270)

4:1 Approximate Safety Factor

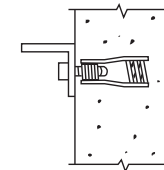

BRACKETS

BOLT DIAMETER AND SYMBOL	MIN. CONC. THICKNESS inch (mm)	INSERT LENGTH inch (L-mm)	INSERT WIDTH inch (O-mm)	WASHER THICKNESS inch (T-mm)	WORKING LOAD lbs (kN)	
					SHEAR	TENSION
3/4" 2 Strut Type EC-2	6" (150)	4 3/4" (121)	2 1/4" (57)	1/8" (3.10)	3,525 lbs. (15.65)	4,500 lbs. (20.00)
1" 2 Strut Type EC-2	6" (150)	5 3/4" (146)	2 5/8" (67)	3/16" (4.70)	6,000 lbs. (26.70)	6,000 lbs. (26.70)

4:1 Approximate Safety Factor

SIZE AND TYPE	FORCE IN kN (lbs) FOR EDGE DISTANCE - CENTERLINE OF INSERT TO NEAREST EDGE															
	1 1/2" (40mm)		2" (50mm)		3" (75mm)		4" (100mm)		5" (125mm)		6" (150mm)		8" (200mm)		9" (225mm)	
	TENSION SHEAR	TENSION SHEAR	TENSION SHEAR	TENSION SHEAR	TENSION SHEAR	TENSION SHEAR	TENSION SHEAR	TENSION SHEAR	TENSION SHEAR	TENSION SHEAR	TENSION SHEAR	TENSION SHEAR	TENSION SHEAR	TENSION SHEAR		
3/4" Type EC-2 2 Strut	1,125 (5.00)	375 (1.60)	2,250 (10.00)	600 (2.60)	3,150 (14.00)	975 (4.30)	3,975 (17.60)	1,350 (6.00)	4,500* (20.00)	3,375 (15.00)	15.60* (3,525*)				4,500* (20.00*)	3,525* (15.60*)
1" Type EC-2 2 Strut					3,375 (15.00)	1,500 (6.60)	4,125 (18.30)	2,250 (10.00)	5,250 (23.30)	3,375 (15.00)	6,000* (26.70*)	4,500 (20.00)	6,000* (26.70*)		6,000* (26.70*)	6,000* (26.70*)

Type EC-4

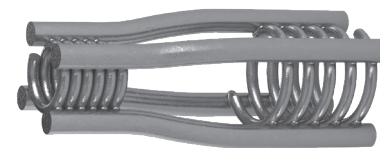

INSERT TYPE	DIA.	LENGTH inch (mm)	WIDTH inch (mm)	WASHER THICKNESS inch (mm)
EC-4	(1 1/4")	7 5/8" (191)	3 1/4" (83)	7/32" (270)

4:1 Approximate Safety Factor

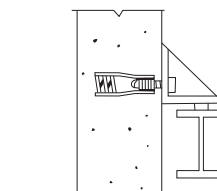

PRECAST ANCHORING TO STEEL

BOLT DIAMETER AND SYMBOL	MIN. CONC. THICKNESS inch (mm)	INSERT LENGTH inch (L-mm)	INSERT WIDTH inch (O-mm)	WASHER THICKNESS inch (T-mm)	WORKING LOAD lbs (kN)	
					SHEAR	TENSION
1 1/4" 4 Strut Type EC-4	8" (200)	7 5/8" (194)	3 1/4" (83)	7/32" (5.50)	9,000 lbs. (40.00)	12,000 lbs. (53.00)

4:1 Approximate Safety Factor

SIZE AND TYPE	FORCE IN kN (lbs) FOR EDGE DISTANCE - CENTERLINE OF INSERT TO NEAREST EDGE															
	1 1/2" (40mm)		2" (50mm)		3" (75mm)		4" (100mm)		5" (125mm)		6" (150mm)		8" (200mm)		9" (225mm)	
	TENSION SHEAR	TENSION SHEAR	TENSION SHEAR	TENSION SHEAR	TENSION SHEAR	TENSION SHEAR	TENSION SHEAR	TENSION SHEAR	TENSION SHEAR	TENSION SHEAR	TENSION SHEAR	TENSION SHEAR	TENSION SHEAR	TENSION SHEAR		
1 1/4" Type EC-4 4 Strut					6,000 (26.70)	2,400 (10.60)	7,500 (33.30)	3,750 (16.50)	9,000 (40.00)	5,625 (25.00)	11,250 (50.00)	8,250 (36.50)	12,000* (53.00*)	9,000* (40.00*)		

Type EC-6

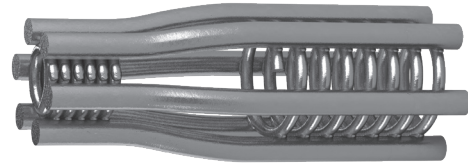

INSERT TYPE	DIA.	LENGTH inch (mm)	WIDTH inch (mm)	WASHER THICKNESS inch (mm)
EC-6	(1 1/2")	9 1/2" (242)	4 3/8" (114)	7/32" (270)

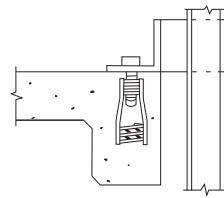

CURTAIN WALL ANCHORAGE TO CONCRETE

4:1 Approximate Safety Factor

BOLT DIAMETER AND SYMBOL	MIN. CONC. THICKNESS inch (mm)	INSERT LENGTH inch (L-mm)	INSERT WIDTH inch (O-mm)	WASHER THICKNESS inch (T-mm)	WORKING LOAD lbs (kN)	
					SHEAR	TENSION
1 1/2" 6 Strut Type EC - 6	12" (300)	9 1/2" (242)	4 3/8" (114)	7/32" (5.50)	12,000 lbs. (53.40)	18,000 lbs. (80.00)

*All so available 1" 4 Strut EC - 4

NOTE: Ferrule type inserts are approximately 1/4 (6mm) longer than coil type inserts.

4:1 Approximate Safety Factor

SIZE AND TYPE	FORCE IN kN (lbs) FOR EDGE DISTANCE - CENTERLINE OF INSERT TO NEAREST EDGE										
	1 1/2" (40 mm)	2" (50 mm)	3" (75 mm)	4" (100 mm)	5" (125 mm)	6" (150 mm)	8" (200 mm)	9" (225 mm)			
	TENSION SHEAR	TENSION SHEAR	TENSION SHEAR	TENSION SHEAR	TENSION SHEAR	TENSION SHEAR	TENSION SHEAR	TENSION SHEAR			
1 1/2" Type EC-6 6 Strut						10,500 (46.70)	6,750 (30.00)	15,000 (66.00)	9,675 (43.00)	18,000* (80.00*)	12,000* (53.00*)

* Maximum insert load capacity. 20 Mpa concrete (3000 psi)

SETTING

Type L, EC-2, EC-4 and EC-6 Inserts can be set with a template bolt. Template bolt provides clearance for final bolt without necessity of plug. Type LFW, EC-2W, EC-4W and EC-6W have a flat washer base with nail holes for nailing or cementing to the forms and can be furnished with an Ethafoam filler to provide clearance for the final bolt. Removal of the Ethafoam filler clears the insert for engagement of the final holding bolt. Type LF, ECF -2, ECF-4 and ECF-6 Inserts can be set with a standard machine bolt, or Plastic Setting Plug.

LT2 & LT4 Lifting Tyscru

Lifting Tyscru are used for thin walled hollow girders where the load distribution must be placed in the compression area of the prestressed girder. LT2 Tyscru with 2 struts are used for moderate loads and LT4 Tyscru with 4 struts are used for heavier loads.

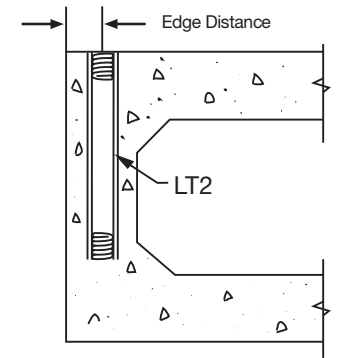

LT2
2 Strut Lifting Tyscru



LT4
4 Strut Lifting Tyscru

Fastener must engage coil completely and protrude a minimum distance of 1 bolt diameter.

4:1 Approximate Safety Factor

LIFTING TYSCRU SIZE AND TYPE	EDGE DISTANCE - CENTERLINE OF INSERT TO NEAREST EDGE																		
	40 mm (1 1/2")		50 mm (2")		75 mm (3")		100 mm (4")		125 mm (5")		150 mm (6")		200 mm (8")		230 mm (9")		300 mm (12")		
	TENSION SHEAR	kN (lbs) SHEAR	TENSION SHEAR	kN (lbs) SHEAR	TENSION SHEAR	kN (lbs) SHEAR	TENSION SHEAR	kN (lbs) SHEAR	TENSION SHEAR	kN (lbs) SHEAR	TENSION SHEAR	kN (lbs) SHEAR	TENSION SHEAR	kN (lbs) SHEAR	TENSION SHEAR	kN (lbs) SHEAR	TENSION SHEAR	kN (lbs) SHEAR	
LT2 Tyscru** 1/2" x 4" (12 x 100 mm)	750 (3.33)	300 (1.33)	6.67 (1,500)	2.33 (525)	2,250* (10.00)	900 (4.00)	5.33 (1,200)	7.34* (1,650)										10.00 (2,250)	7.34* (1,650)
LT2 Tyscru** 1/2" x 6" (12 x 150 mm)	975 (4.33)	300 (1.33)	8.67 (1,950)	2.33 (525)	3,000* (13.34)	900 (4.00)	5.33 (1,200)	7.34* (1,650)										13.34* (3,000)	7.34 (1,650)
LT2 Tyscru 3/4" x 6" (20 x 150 mm)	5.00 (5.00)	1.66 (1.66)	10.00 (2,250)	2.66 (600)	3,150 (14.00)	975 (4.33)	16.70* (3,750)	6.00 (1,350)	10.00 (2,250)	15.68* (3,525)								16.70* (3,750)	15.68 (3,525)
LT2 Tyscru 3/4" x 9" (20 x 230 mm)	1,500 (6.67)	375 (1.66)	12.67 (2,850)	2.66 (600)	3,750 (16.68)	975 (4.33)	20.00 (4,500)	6.00 (1,350)	24.5* (5,500)	10.00 (2,250)	15.68* (3,525)							24.5* (5,500)	15.68* (3,525)
LT2 Tyscru*** 1" x 6" (25 x 150 mm)					3,375 (15.00)	1500 (6.67)	18.35 (4,125)	10.00 (2,250)	23.35 (5,250)	15.00 (3,375)	26.69* (6,000)	20.00 (4,500)	26.69* (6,000)					26.69* (6,000)	26.69* (6,000)
LT2 Tyscru 1" x 12" (25 x 300 mm)					4,500 (20.00)	1500 (6.67)	26.69 (6,000)	10.00 (2,250)	33.36 (7,500)	15.00 (3,375)	36.69* (8,250)	20.00 (4,500)	26.69* (6,000)					36.69* (8,250)	26.69 (6,000)
LT4 Tyscru 1 1/4" x 12" (32 x 300 mm)							33.36 (7,500)	10.67 (2,400)	40.03 (9,000)	16.68 (3,750)	46.70 (10,050)	25.00 (5,625)	60.00 (13,500)	36.69 (8,250)	73.40* (16,500)	40.00 (9,000)	73.40* (16,500)	40.00 (9,000)	
LT4 Tyscru 1 1/2" x 18" (38 x 460 mm)											60.00 (13,500)	30.00 (6,750)	73.40* (16,500)	43.37 (9,750)	53.38* (12,000)	73.40* (16,500)	65.71 (14,770)		

20 MPa 3000 psi

*Maximum Insert load capacity. **Available but not recommended. ***Custom order 1" LT4 available

Lift Lags (LLAG)

AR Lift Lags are used for anchoring lifting fixtures, etc., and are available in 3/4", 1", 1 1/4", 1 1/2" (20, 25, 32, and 38) mm sizes. Bolts are threaded to within 1/2" (12 mm) of the bolt head. To order, give diameter, length, symbol and name.

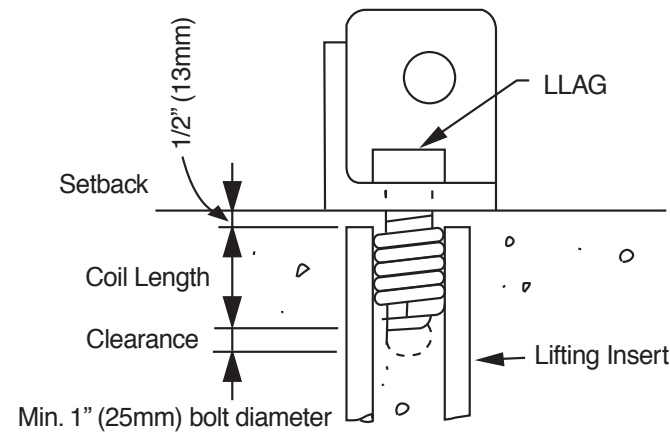

4:1 Approximate Safety Factor

DIA-TYPE	STRAIGHT	45*	90*
3/4" (20 mm) LDLP Swivel Lift Plate	7,280 lbs (32.38 kN)	4,800 lbs (21.35 kN)	4,800 lbs (21.35 kN)
1" LDLP (25 mm)	13,890 lbs (61.74 kN)	8,460 lbs (37.63 kN)	8,460 lbs (37.63 kN)
1 1/4" (32 mm) LDLP Swivel Lift Plate	21,700 lbs (96.52 kN)	14,350 lbs (63.83 kN)	14,350 lbs (63.83 kN)
1 1/2" LDLP (38 mm)	23,747 lbs (105.64 kN)	21,700 lbs (96.52 kN)	21,700 lbs (96.52 kN)

* Limited by Swivel Plate (LDLP) capacity

Inspect all lift lags for bolt damage such as cracks, bent shank, worn threads and other signs or bolt damage. Damaged products are not to be reused.

To prolong bolt life, bolts should not be overloaded beyond the values shown in these tables. If overload conditions have been experienced, the bolts should not be used.

Surface Lift

The AR Surface Lift Products listed in this section are designed to allow precast panels to be handled multiple times, with quick engagement and disengagement during lifting, saving labour costs. Products are marked with maximum safe working loads and are hot-dipped galvanized for better corrosion resistance and durability.

Quick Pin

The AR Quick Pin and Utility anchors are hot forged from ASTM A572-15 Grade 50 carbon steel. The advantage of forged steel is that it eliminates the needs for welds or thread engagement, resulting in stronger anchors and allowing them to meet the required 4 to 1 Approximate Safety Factor. The formed head which has the load rating stamped in, engages in the corresponding Lifting Clutch, while the disc shaped foot is embedded in the concrete.

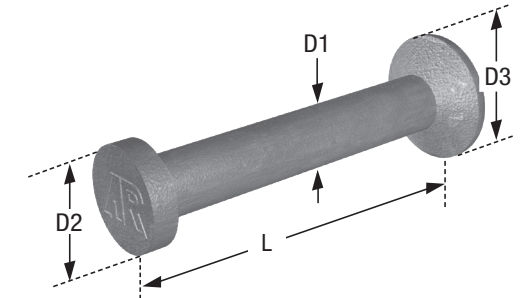

4:1 Approximate Safety Factor

Load Rating	Length	Shaft Diameter D1		Head Diameter D2		Foot Diameter D3		4:1 SWL (lbs)	Ultimate Tensile Load (lbs)
		mm	in	mm	in	mm	in		
2T	Various	14	9/16"	25	1"	35	1-3/8"	4,400	17,600
4T	Various	20	3/4"	36	1-13/32"	50	2"	8,800	35,200
8T	Various	28	1-7/64"	47	1-27/32"	70	2-3/4"	17,600	70,400
12T	Various	34	1-11/32"	69	2-3/4"	85	3-11/32"	26,400	105,600
16T	Various	38	1-1/2"	69	2-3/4"	98	3-7/8"	35,200	140,800
25T	Various	50	2"	88	3-1/2"	135	5-5/16"	55,000	220,000

Quick Pin with Lifting Eye

The AR Quick Pin Eye is primarily used in thin panels and allows for rebar to be inserted through the eye of the anchor. Additional sizes available on request.

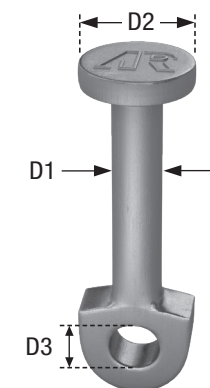

4:1 Approximate Safety Factor

Load Rating	Length		Shaft Diameter D1		Head Diameter D2		Foot Diameter D3		4:1 SWL (lbs)	Ultimate Tensile Load (lbs)
	mm	in	mm	in	mm	in	mm	in		
1T	65	2-1/2"	10	3/8"	18	11/16"	10	3/8"	2,200	8,800
2T	90	3-1/2"	14	9/16"	25	1"	13	1/2"	4,400	17,600
4T	120	4-3/4"	20	3/4"	36	1-7/16"	20	3/4"	8,800	35,200
8T	180	7-1/16"	28	1-1/8"	46	1-13/16"	25	1"	17,600	70,400
20T	250	9-7/8"	38	1-1/2"	69	2-3/4"	38	1-1/2"	44,000	176,000

Double Head Quick Pin

The AR Double Head Quick Pin is a special version of the standard Quick Pin. It is designed for concrete pipe precasters where automatic equipment is used to handle the pins and corresponding void formers. The heads are machined with precision to ensure a proper seal with the void former, and the load rating on the head is recessed, which allows a uniform contact with the magnetic locators. Additional sizes available on request.

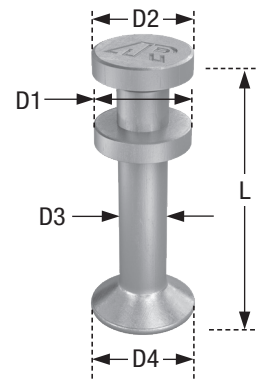

4:1 Approximate Safety Factor

Load Rating	Length		Shaft Diameter D1		Head Diameter D2		Head Diameter D3		Foot Diameter D4		4:1 SWL (lbs)	Ultimate Tensile Load (lbs)
	mm	in	mm	in	mm	in	mm	in	mm	in		
1T	85	3-3/8"	10	3/8"	18	11/16"	18	11/16"	25	1"	2,200	8,800
2T	85	3-3/8"	14	9/16"	25	1"	25	1"	35	1-3/8"	4,400	17,600
2T	90	3-1/2"	14	9/16"	25	1"	25	1"	35	1-3/8"	4,400	17,600
4T	85	3-3/8"	20	3/4"	36	1-7/16"	36	1-7/16"	50	2"	8,800	35,200
4T	90	3-1/2"	20	3/4"	36	1-7/16"	36	1-7/16"	50	2"	8,800	35,200
4T	95	3-3/4"	20	3/4"	36	1-7/16"	36	1-7/16"	50	2"	8,800	35,200
4T	110	4-1/4"	20	3/4"	36	1-7/16"	36	1-7/16"	50	2"	8,800	35,200

Utility V-Anchor

The AR Quick Pin and Utility anchors are hot forged from ASTM A572-15 Grade 50 carbon steel. The advantage of forged steel is that it eliminates the needs for welds or thread engagement, resulting in stronger anchors and allowing them to meet the required 4 to 1 Approximate Safety Factor. Anchors are available in two different wire diameters: 0.444" and 0.671". The disc shaped feet are both embedded in concrete and allow a standard hook to be used for lifting. All anchors are hot-dipped galvanized for ultimate rust protection.

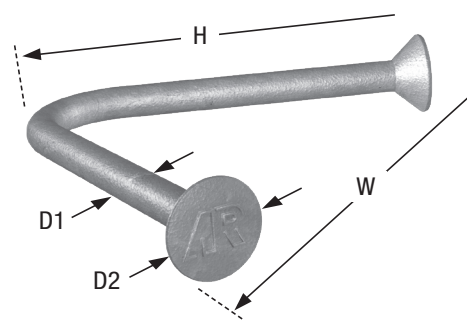

4:1 Approximate Safety Factor

Wire Diameter, D1		Slab Thickness		Height (H)		Width (W)		Foot Diameter, D2		Anchor Marking	Ultimate Tensile Load (lbs)	4:1 SWL (lbs)
in	mm	in	mm	in	mm	in	mm	in	mm			
0.444"	11	4"	102	3-1/8"	79	5-1/4"	133	1-1/4"	31	.444-4	12,800	3,200
0.444"	11	5"	127	3-3/4"	95	6"	152	1-1/4"	31	.444-5	15,400	3,850
0.444"	11	6"	152	4-3/4"	121	7-3/8"	183	1-1/4"	31	.444-6	17,840	4,460
0.671"	17	5"	127	3-3/4"	95	6-7/16"	164	1-9/16"	40	.671-5	18,240	4,560
0.671"	17	6"	152	4-3/4"	121	7-3/8"	192	1-9/16"	40	.671-6	29,280	7,320
0.671"	17	8"	203	6-3/4"	171	9-3/4"	251	1-9/16"	40	.671-8	43,320	10,830

U-Anchor

The AR U-Anchors are ideal for thin wall concrete slabs and small retaining wall blocks. The anchors can be either recessed using a void former, or can protrude from the concrete.

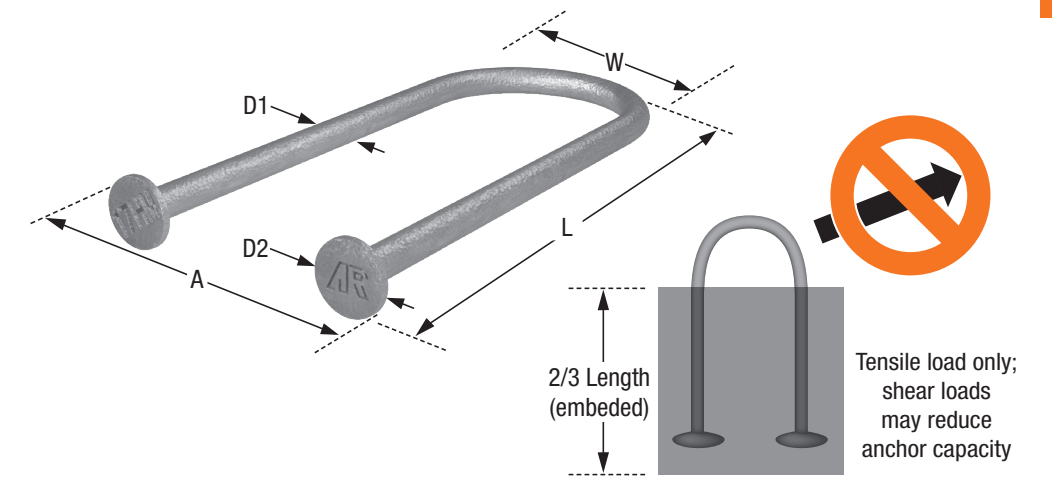

4:1 Approximate Safety Factor

Load Rating (Ton)	Length (L)		Width (W)		Wire Diameter (D1)		Foot Diameter (D2)		A		4:1 SWL (lbs)
	mm	in	mm	in	mm	in	mm	in	mm	in	
1/4" x 6"	152	6"	67	2-5/8"	6	1/4"	12	1/2"	73	2-7/8"	640
5/16" x 6-1/2"	165	6-1/2"	67	2-5/8"	8	5/16"	18	3/4"	76	3"	1,320
3/8" x 7"	178	7"	70	2-3/4"	10	3/8"	25	1"	83	3-1/4"	1,936
7/16" x 9"	229	9"	89	3-1/2"	11	7/16"	25	1"	98	3-7/8"	2,992
7/16" x 11"	279	11"	89	3-1/2"	11	7/16"	25	1"	98	3-7/8"	2,992
Heavy Duty - 5/8" x 16-1/2"	419	16-1/2"	191	7-1/2"	16	5/8"	-	-	292	11-1/2"	4,270

Plate Anchor

The AR Plate Anchor is a low profile anchor ideal for face/back lifts of thin-walled concrete precast structures. The wide base plate allows for high pull out loads in concrete and permits the anchor to be secured to rebar, which further increases the safe working loads.

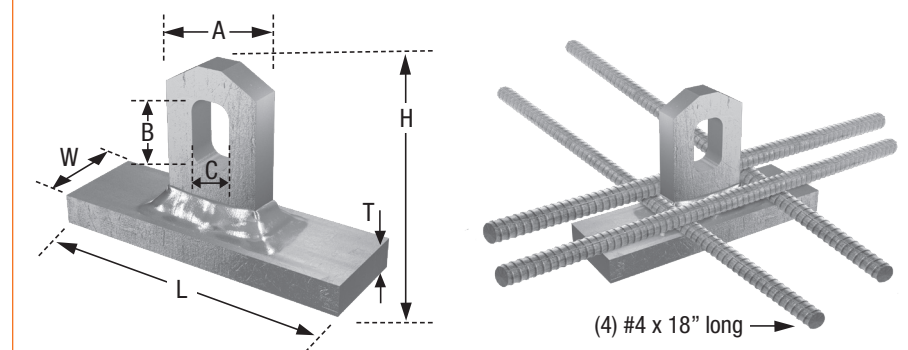

4:1 Approximate Safety Factor

Load Rating (Ton)	Height (H)		Length (L)		Width (W)		Anchor Width (A)		Thickness (T)		B		C		Tension SWL	
	mm	in	mm	in	mm	in	mm	in	mm	in	mm	in	mm	in	KN	LBS
2T	57	2-1/4"	95	3-3/4"	30	1-3/16"	30	1-3/16"	10	3/8"	20	3/4"	14	1/2"	4.45	1,000
4T	75	3"	75	3"	40	1-1/2"	40	1-1/2"	15	5/8"	22	7/8"	18	3/4"	15.56	3,500
4T	90	3-1/2"	75	3"	40	1-1/2"	40	1-1/2"	15	5/8"	22	7/8"	18	3/4"	20.89	4,700
4T	110	4-3/8"	100	3-7/8"	40	1-1/2"	40	1-1/2"	15	5/8"	22	7/8"	18	3/4"	21.11	4,750
8T	160	6-1/4"	127	5"	64	2-1/2"	64	2-1/2"	19	3/4"	30	1-3/16"	26	1"	28.22	6,350
8T	180	7-1/8"	127	5"	64	2-1/2"	64	2-1/2"	19	3/4"	30	1-3/16"	26	1"	44.45	10,000

Two Hole Anchor

The AR Two Hole Anchor is ideal for lifting and handling thin-walled concrete precast elements. The use of a tension bar, which can be inserted through the bottom hole, is required to distribute the forces developed during the lifting process into the concrete.

4:1 Approximate Safety Factor

Load Rating (Ton)	Length (L)		Width (W)		Thickness (T)		A		B		4:1 SWL (lbs)	Ultimate Tensile Load (lbs)
	mm	in	mm	in	mm	in	mm	in	mm	in		
2T	90	3-1/2"	30	1-3/16"	10	3/8"	20	3/4"	14	9/16"	4,400	17,600
4T	120	4-3/4"	40	1-1/2"	15	5/8"	22	7/8"	18	3/4"	8,800	35,200
6T	160	6-1/4"	60	2-3/8"	15	5/8"	30	1-3/16"	26	1"	13,200	52,800
8T	165	6-1/2"	60	2-3/8"	19	3/4"	30	1-3/16"	26	1"	17,600	70,400

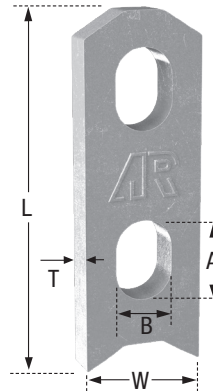

Panel Pick Anchor

The AR Panel Pick anchor is hot forged and used for surface lift applications. This anchor can be wet set, or used with the AR Plate Anchor Void former (4T-5T). The disc shaped foot is embedded in concrete, while the top of the anchor allows for an AR Ring Clutch to be used for lifting. Anchors are available in 6T load rating, and are hot-dipped galvanized. Additional sizes and loads available on request.

4:1 Approximate Safety Factor

Load Rating (Ton)	Height (H)		Thickness (T)		Width (W)		Foot Diameter (D)		Ultimate Tensile Load (lbs)
	mm	in	mm	in	mm	in	mm	in	
6T	120	4-3/4"	16	5/8"	38	1-1/2"	48	1-7/8"	50,000
6T	140	5-1/2"	16	5/8"	38	1-1/2"	48	1-7/8"	50,000
6T	150	5-7/8"	16	5/8"	38	1-1/2"	48	1-7/8"	50,000

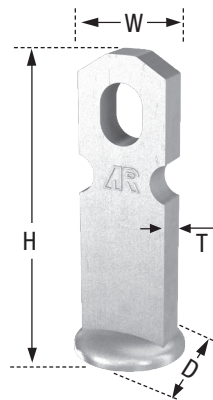

T-Bar Anchor

The AR T-Bar Anchors use a round bar inserted through the bottom anchor hole to increase pull out loads, ideal for back-stripping and panel rotation applications. Allow 3/8" setback on each side of the anchor.

4:1 Approximate Safety Factor

Load Rating (Ton)	Length (L)		Width (W)		Thickness (T)		Bar Diameter (D)		A		B		4:1 SWL (lbs)	Ultimate Tensile Load (lbs)
	mm	in	mm	in	mm	in	mm	in	mm	in	mm	in		
2T	100	4"	30	1-1/4"	10	3/8"	12.5	1/2"	20	3/4"	14	9/16"	4,400	17,600
4T	110	4-1/4"	40	1-1/2"	15	5/8"	17.5	11/16"	22	7/8"	18	3/4"	8,800	35,200
4T	135	5-1/4"	40	1-1/2"	15	5/8"	17.5	11/16"	22	7/8"	18	3/4"	8,800	35,200
4T	160	6-1/4"	40	1-1/2"	15	5/8"	17.5	11/16"	22	7/8"	18	3/4"	8,800	35,200
4T	185	7-1/4"	40	1-1/2"	15	5/8"	17.5	11/16"	22	7/8"	18	3/4"	8,800	35,200

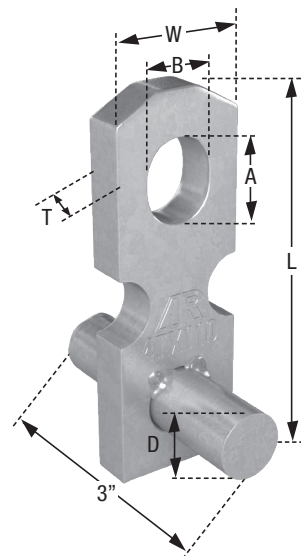

Wire Rope

The AR Wire Rope, shaped like a figure 8, is an economical lifting system (no Void Former required) typically used for utility applications. Each wire is secured by a swage clamp, has a colour coded tag showing the Safe Working tensile load rating and is galvanized for ultimate rust protection. Safe Working Loads range from 1,600 LBS to 50,000 LBS, with a safety factor of approximately 4 to 1.

4:1 Approximate Safety Factor

Part Number	Tag Colour	Safe Working Load (Ton)	Safe Working Load Tension 4:1 (LBS)*	W - Wire Width		H - Wire Height		D - Wire Diameter (mm)
				in	mm	in	mm	
PP-10-0.8TWRG	White	0.8	1,600	4"	102	8-1/4"	210	6
PP-10-1.2TWRG	Red	1.2	2,400	4-3/8"	111	8-7/8"	225	7
PP-10-1.6TWRG	Purple	1.6	3,200	4-3/4"	121	9-1/4"	235	8
PP-10-2.0TWRG	Green	2.0	4,000	5-1/8"	130	11"	279	9
PP-10-2.5TWRG	Dark Grey	2.5	5,000	5-1/2"	140	12-1/8"	308	10
PP-10-4.0TWRG	Yellow	3.8	7,600	6-1/4"	159	13-1/2"	343	12
PP-10-5.2TWRG	Dark Blue	5.0	10,000	7-3/8"	187	15-1/4"	387	14
PP-10-6.3TWRG	Light Blue	6.3	12,600	8"	203	16-3/4"	425	16
PP-10-8.0TWRG	Light Grey	8.0	16,000	9-3/8"	238	19-3/8"	492	18
PP-10-10.0TWRG	Pink	10.0	19,800	10-3/4"	273	21"	533	20
PP-10-12.5TWRG	Black	12.0	24,000	11-1/8"	283	22-7/8"	581	22
PP-10-16.0TWRG	Brown	16.0	32,000	13-1/4"	337	25-1/2"	648	26
PP-10-20.0TWRG	Orange	18.0	36,000	14"	356	28-1/2"	724	28
PP-10-25.0TWRG	Tan	25.0	50,000	16-1/2"	419	33-1/4"	845	32

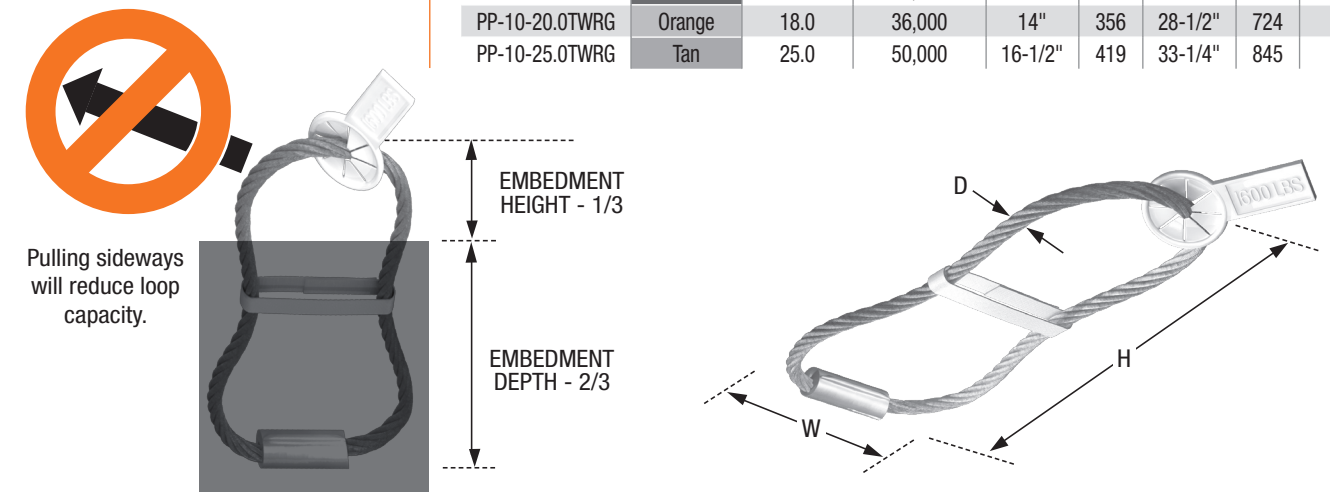

Wire Loop with Eye Bolt

The AR Wire Loop with Eye Bolt is a wire rope loop that is swaged and has a threaded bolt to allow use in edge lift applications with metric threaded inserts or Wavy Tail anchors. Each loop comes with a colour coded tag showing the anchor capacity, ranging from 1,100 - 12,600 lbs.

4:1 Approximate Safety Factor

Load Rating (Tons)	Tag Colour	Thread Size (mm)	Length L		Wire Diameter D		Thread Depth E	
			in	mm	in	mm	in	mm
0.5T	Brown	M12	335	13-1/8"	8	5/16"	22	7/8"
1.2T	Red	M16	385	15-1/8"	8	5/16"	24	15/16"
2.0T	Light Green	M20	470	18-1/2"	10	3/8"	35	1-3/8"
2.5T	Dark Grey	M24	550	21-1/2"	12	15/32"	35	1-3/8"
4.0T	Green	M30	590	23-1/4"	16	21/32"	45	1-25/32"
6.3T	Blue	M36	780	30-3/4"	18	23/32"	65	2-9/16"

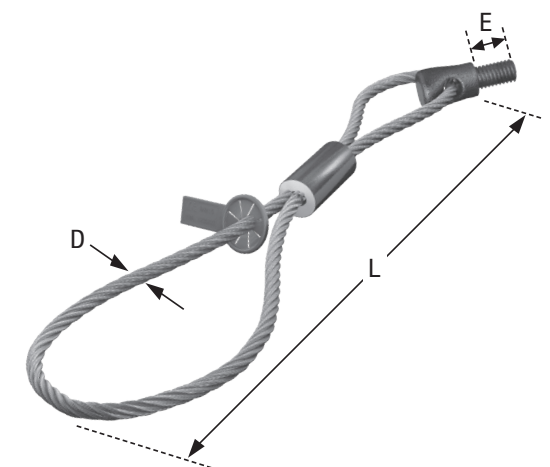

Threaded Wire Ropes

The AR Threaded Wire Rope Loop is a galvanized wire rope to be used with threaded inserts and is available for M12, 16, 20, 24, 30, 36, 42 and 52 metric threads. Safe Working Loads range from 1,100 LBS to 27,500 LBS with a Approximate Safety Factor of approximately 4 to 1.

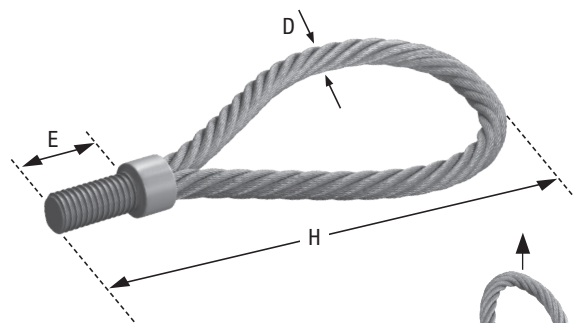

4:1 Approximate Safety Factor

Part Number	Safe Working Load Tension (KG)*	Safe Working Load Tension (LBS)*	Ultimate Tensile Load (LBS)	Thread Size (mm)	Height, H (mm)	Thread Depth, E (mm)	Wire Rope Diameter, D (mm)
M12WRLG	500	1,100	4,400	M12	155	22	6
M16WRLG	1,200	2,640	10,560	M16	155	27	8
M20WRLG	2,000	4,400	17,600	M20	215	40	10
M24WRLG	2,500	5,500	22,000	M24	255	43	12
M30WRLG	4,000	8,800	35,200	M30	300	60	16
M36WRLG	6,300	13,860	55,440	M36	340	70	18
M42WRLG	8,000	17,600	70,400	M42	425	75	20
M52WRLG	12,500	27,500	110,000	M52	550	80	26

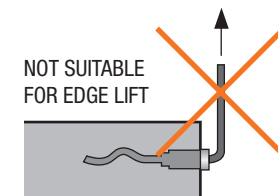
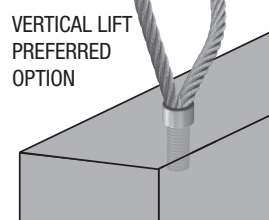

To be used for straight tensile loads only, do not use under shear loading conditions

Wavy Tail Anchor

The AR Wavy Tail Anchor is an economic alternative to lifting precast units. The socket has metric thread and is swaged to a wave shaped rebar, available in two different lengths. Short anchors are typically used in beams, whereas long anchors are typically used in panels.

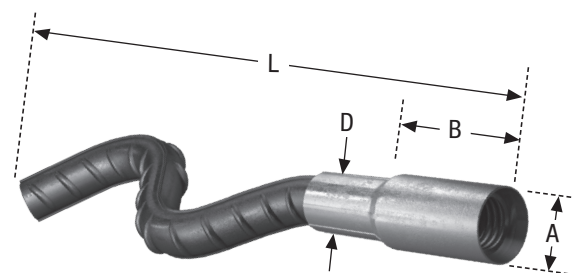

4:1 Approximate Safety Factor

Anchor Thread	Length (L)		A		B		D		Load (KG)	Ultimate Tensile Load (lbs)	4:1 SWL (lbs)
	mm	in	mm	in	mm	in	mm	in			
M12	108	4-1/4"	17	11/16"	22	7/8"	8	5/16"	575	5,060	1,265
M12	137	5-11/32"	17	11/16"	22	7/8"	8	5/16"	575	5,060	1,265
M16	167	6-1/2"	22	7/8"	27	1-1/16"	12	15/32"	1,200	10,560	2,640
M16	216	8-1/2"	22	7/8"	27	1-1/16"	12	15/32"	1,200	10,560	2,640
M20	187	7-3/8"	28	1-1/8"	35	1-3/8"	14	1/2"	2,050	18,040	4,510
M20	257	10-1/8"	28	1-1/8"	35	1-3/8"	14	1/2"	2,050	18,040	4,510
M24	240	9-7/16"	32	1-1/4"	43	1-11/16"	16	21/32"	2,500	22,000	5,500
M24	360	14-3/16"	32	1-1/4"	43	1-11/16"	16	21/32"	2,500	22,000	5,500

Erection Anchor

The AR Erection Anchor is used for vertical edge lifts of thin-walled concrete precast elements. The anchor head features two spikes which serve to prevent concrete spalling by restricting rotation of the ring clutch, therefore transmitting lateral forces to the anchor rather than the concrete. The use of a shear bar is required with this anchor which can be inserted using the bottom two holes.

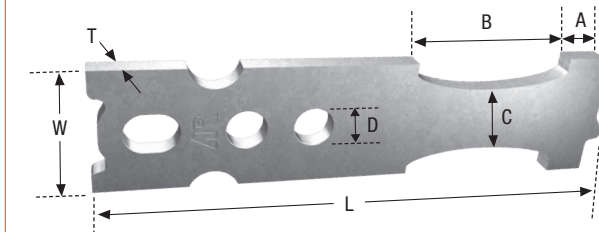

4:1 Approximate Safety Factor

Load Rating	Anchor												4:1 SWL (lbs)	Ultimate Tensile Load (lbs)		
	Length (L)		Width (W)		Thickness (T)		A		B		C				Hole Diameter-D	
2T	222	8-3/4"	51	2"	10	3/8"	16	5/8"	50	2"	35	1-3/8"	16	5/8"	4,400	17,600
4T	267	10-1/2"	64	2-1/2"	16	5/8"	19	3/4"	63	2-1/2"	42	1-5/8"	19	3/4"	8,800	35,200
8T	327	12-7/8"	95	3-3/4"	19	3/4"	25	1"	89	3-1/2"	76	3"	25	1"	17,600	70,400

Erection Anchor with Shear Plate

The AR Erection Anchor with shear plate eliminates the need for a shear bar. All other features are the same as the standard anchor.

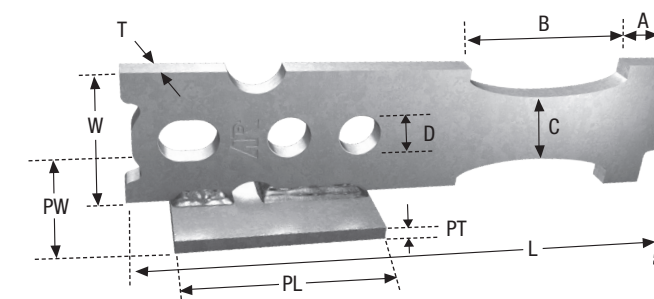

4:1 Approximate Safety Factor

Load Rating	Anchor												Shear Plate				4:1 SWL (lbs)	Ultimate Tensile Load (lbs)				
	Length (L)		Width (W)		Thickness (T)		A		B		C		Hole Diameter-D		Length (PL)				Width (PW)		Thickness (PT)	
2T	222	8-3/4"	51	2"	10	3/8"	16	5/8"	50	2"	35	1-3/8"	16	5/8"	76	3"	64	2-1/2"	6	1/4"	4,400	17,600
4T	267	10-1/2"	64	2-1/2"	16	5/8"	19	3/4"	63	2-1/2"	42	1-5/8"	19	3/4"	76	3"	64	2-1/2"	10	3/8"	8,800	35,200
8T	327	12-7/8"	95	3-3/4"	19	3/4"	25	1"	89	3-1/2"	76	3"	25	1"	89	3-1/2"	76	3"	10	3/8"	17,600	70,400

Forged Erection Anchor

The AR Forged Erection Anchor is used for vertical edge lifts of thin-walled concrete precast elements. The anchor head features two spikes which serve to prevent concrete spalling by restricting rotation of the ring clutch, therefore transmitting lateral forces to the anchor rather than the concrete. The notch on the side of the anchor accommodates the use of a shear bar if desired. The two holes can accommodate a tension bar or rebar for greater load capacities.

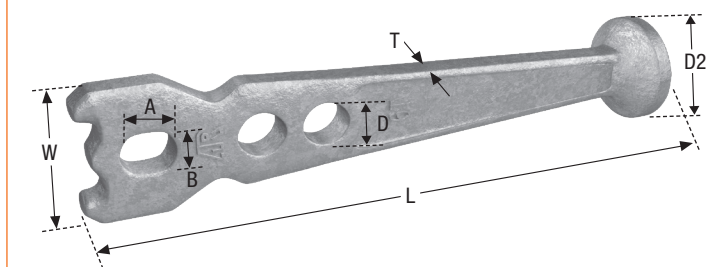

4:1 Approximate Safety Factor

Load Rating	Length (L)		Width (W)		Thickn. (T)		Hole Diam. (D)		A		B		4:1 SWL (lbs)	Ultimate Tensile Load (lbs)
	mm	in	mm	in	mm	in	mm	in	mm	in	mm	in		
3T	203	8"	51	2"	11	7/16"	16	5/8"	21	13/16"	14	9/16"	6,600	26,400
6T	268	10-1/2"	64	2-1/2"	16	5/8"	19	3/4"	23	29/32"	18	3/4"	13,200	52,800
10T	324	12-3/4"	109	4-1/4"	19	3/4"	26	1"	30	1-3/16"	26	1"	22,000	88,000

Forged Erection Anchor with Shear Plate

The AR Forged Erection Anchor is hot forged, with other features being the same as the Standard Erection Anchor with shear plate. The notch on the side of the anchor accommodates the use of a shear bar if desired. The two holes can accommodate a tension bar or rebar for greater load capacities.

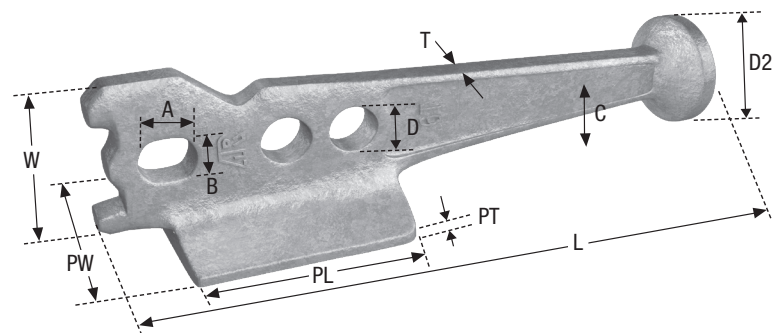

4:1 Approximate Safety Factor

Load Rating	Anchor												Shear Plate						4:1 SWL (lbs)	Ultimate Tensile Load (lbs)		
	Length (L)		Width (W)		Thickn. (T)		Hole Diam. (D)		A		B		Foot Diam. (D2)		Length (PL)		Width (PW)				Thickn. (PT)	
	mm	in	mm	in	mm	in	mm	in	mm	in	mm	in	mm	in	mm	in	mm	in	mm	in		
6T	268	10-1/2"	73	2-7/8"	17	5/8"	22.5	7/8"	23	29/32"	18	3/4"	50	2"	100	3-15/16"	80	3.150	12	0.472	13,200	52,800
10T	324	12-3/4"	109	4-1/4"	20	3/4"	26	1"	30	1-3/16"	26	1"	70	2-3/4"	102	4"	82	3.228	12	0.472	22,000	88,000

Sandwich Panel Erection Anchor

The AR Sandwich Panel Erection Anchor is designed to be used for edge lift of insulated sandwich panels with 2"-4" thickness. The anchor head features two spikes which serve to prevent concrete spalling by restricting rotation of the ring clutch, therefore transmitting lateral forces to the anchor rather than the concrete. Two bent rebars must be inserted through the bottom holes of the anchor to achieve full working loads.

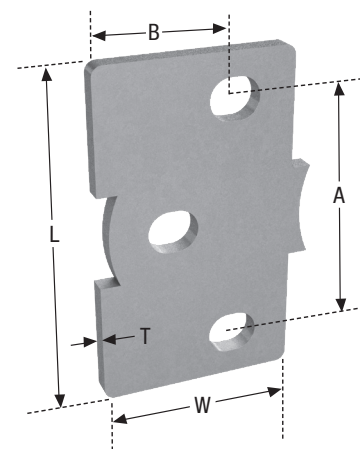

4:1 Approximate Safety Factor

Load Rating	Anchor										4:1 SWL (lbs)	Ultimate Tensile Load (lbs)
	Length (L)		Width (W)		Thickn. (T)		A		B			
	mm	in	mm	in	mm	in	mm	in	mm	in		
4T	152	6"	82	3-1/4"	16	5/8"	111	4-3/8"	48	1-7/8"	8,800	35,200
8T	152	6"	120	4-3/4"	19	3/4"	111	4-3/8"	86	3-3/8"	17,600	70,400

Sandwich Panel Erection Anchor with Shear Plate

The AR Sandwich Panel Erection Anchor with shear plate improves shear capacity. All other features are the same as the standard Sandwich Panel Erection Anchor.

4:1 Approximate Safety Factor

Load Rating	Anchor										Shear Plate						4:1 SWL (lbs)	Ultimate Tensile Load (lbs)
	Length (L)		Width (W)		Thickn. (T)		A		B		Length (PL)		Width (PW)		Thickn. (PT)			
	mm	in	mm	in	mm	in	mm	in	mm	in	mm	in	mm	in	mm	in		
4T	152	6"	82	3-1/4"	16	5/8"	111	4-3/8"	48	1-7/8"	51	2"	76	3"	10	3/8"	8,800	35,200
8T	152	6"	120	4-3/4"	19	3/4"	111	4-3/8"	86	3-3/8"	76	3"	89	3-1/2"	10	3/8"	17,600	70,400
8T	178	7"	120	4-3/4"	19	3/4"	127	5"	86	3-3/8"	76	3"	102	4"	10	3/8"	17,600	70,400
8T	203	8"	120	4-3/4"	19	3/4"	152	6"	86	3-3/8"	76	3"	102	4"	10	3/8"	17,600	70,400

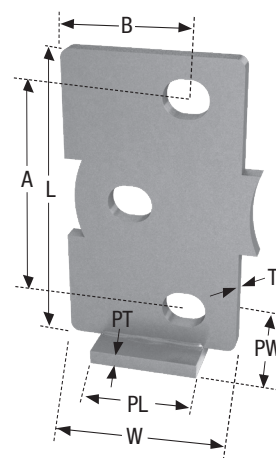

Lifting Bracket (LB)

The Lifting Bracket consists of a heavy angle punched with two holes for bolting to the coils of 12" (300 mm). Double Lifting insert or other tandem anchorage units. A heavy plate is welded to the center of the bracket and is equipped with a hole to engage the lifting shackle.

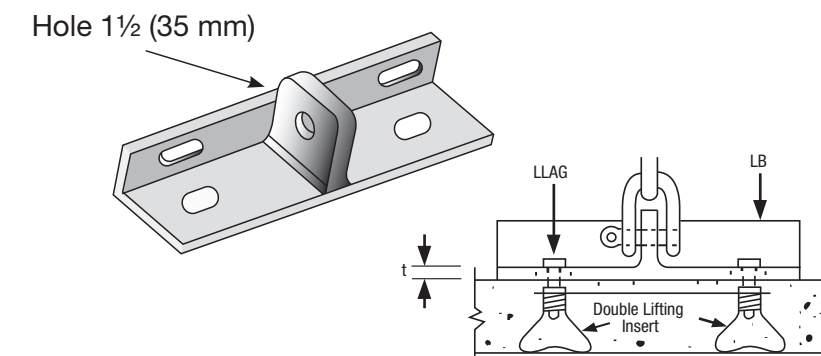

Approximate Safe Working Loads 18,000 lbs./ 80kN

DIAMETER in (mm)	SIZE in (mm)	LENGTH in (mm)	LIFTING HOLE in (mm)	HOLES PACING in (mm)
3/4 (20)	3/4 x 6 x 6 (20 x 150 x 150)	18 (450)	1 3/8 (35)	12 (305)
1 (25)	3/4 x 6 x 6 (20 x 150 x 150)	18 (450)	1 3/8 (35)	12 (305)
1 1/2 (32)	3/4 x 6 x 6 (20 x 150 x 150)	21 (530)	1 5/16 (59)	15 (381)

Heavy Duty Swivel / Pivot Lift Plate (LDLP)

- Pivots 180°/Swivels 360°
- Material: Forged alloy steel
- Approximate Safety Factor: 5:1
- Minimum tensile strength of 180,000 psi.
- Finish: Black Oxide per Mil C-13924B
- 100% Magnetic Particle Inspected (Cadmium plated available)

Bolt/Coil insert not included

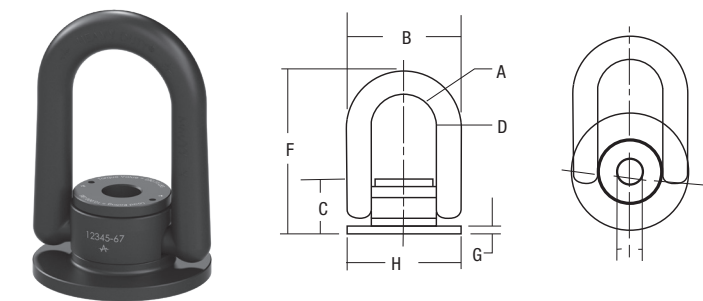

5:1 Approximate Safety Factor

*RATED LOAD	A in (mm)	B in (mm)	C in (mm)	D in (mm)	F in (mm)	G in (mm)	H in (mm)	I in (mm)	WEIGHT lbs (kg)
* 10,000 lbs. (4,500 kg)	1.40 (35.5)	5.10 (130)	2.39 (60)	1.00 (25)	7.00 (178)	13/32 (10)	5 (127)	1 (25)	8.95 (4)
* 24,000 lbs. (10,800 kg)	2.00 (50)	6.75 (170)	3.29 (83)	1.25 (32)	8.90 (220)	1/2 (13)	7 (178)	1-5/8 (41)	20.71 (9.4)

*Note: Rated load is based on 180,000 psi (1240 mpa) ultimate tensile strength of bolt or stud. If a bolt with lower strength is used or workpiece anchor material is incapable of supporting this weight, the applied load must be reduced accordingly

Type K Lifting Eye

The AR Type K Lifting Eye consists of a ring, base and base plate welded together. The Type K Lifting Eye is designed for use with a single bolt to engage any single lifting insert. Available in the size shown in the table below.

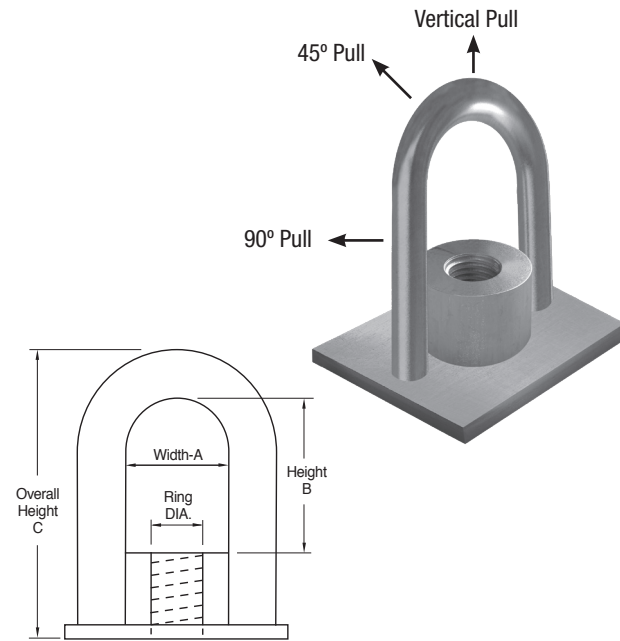

4:1 Approximate Safety Factor

Diameter inch (mm)	Ring Diameter inch (mm)	Straight Tension Ultimate Strength lbs (kN)	90° Tension Ultimate Strength lbs (kN)
1/2 (13)	3/4 (20)	18,000 (80*)	1,400 (6.2*)
3/4 (20)	3/4 (20)	34,000 (150*)	1,400 (6.2*)
1 (25)	1 (25)	75,000 (333*)	3,326 (14.7*)
1 1/4 (32)	1 1/4 (32)	95,000 (422*)	6,975 (31*)

*Recommended minimum Safe Working Load should be 4 to 1 against ultimate. Refer to ASTM for loads reduction calculation off vertical pull. Not available in hot dip galvanized.

Diameter inch (mm)	Internal Thread	Width A inch (mm)	Height B inch (mm)	Height C inch (mm)
1/2 (13)	6 Lag	2 (50)	3 (75)	5 1/2 (140)
3/4 (20)	4.5 Lag	2 (50)	3 (75)	5 1/2 (140)
1 (25)	3.5 Lag	2 (50)	3 (75)	5 1/2 (140)
1 1/4 (32)	3.5 Lag	3 (75)	4 1/2 (115)	8 3/8 (213)

Lifting Eye Bolt

The AR Lifting Eye Bolt is produced from drop forged steel in standard sizes as outlined in the chart below. Values listed are for a Type 2- Shoulder Patterned Eye Bolt and are supplied with a lag or NC thread. The Eye Bolt is designed to develop full strength of the bolt in straight vertical pull. To develop the full lifting capacity, the Eye Bolt must be properly seated and engaged with 1/2" (13 mm) of thread extending beyond the coil end. The loads are to be applied parallel to the eye and never across the plane of the eye. Should other than standard lengths shown be required, specify the required length of thread.

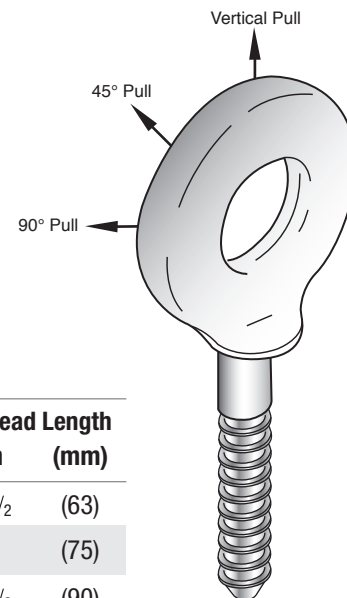

Approximate Safe Working Loads

Bolt Diameter in (mm)	Vertical Pull lbs kN	45° Pull lbs kN	90° Pull lbs kN	Eye Diameter in (mm)	Shank Length in (mm)	Thread Length in (mm)
1 (25)	7,500 (33.4)	1,500 (6.7)	1,100 (4.9)	2 (50)	3 1/2 (90)	3 (75)
1 1/4 (32)	11,600 (51.6)	2,600 (11.6)	1,900 (8.5)	2 (50)	4 (100)	3 1/2 (90)
1 1/2 (38)	16,900 (75.2)	4,100 (18.2)	3,000 (13.3)	2 1/2 (64)	4 1/2 (115)	4 (100)

Quick Pin Clutch

The AR Quick Pin Clutches are available in 2T, 4T and 8T load ratings and are hot dipped galvanized for rust protection. The clutch lifting head is designed for quick and easy attachment to the A-R Quick Pins.

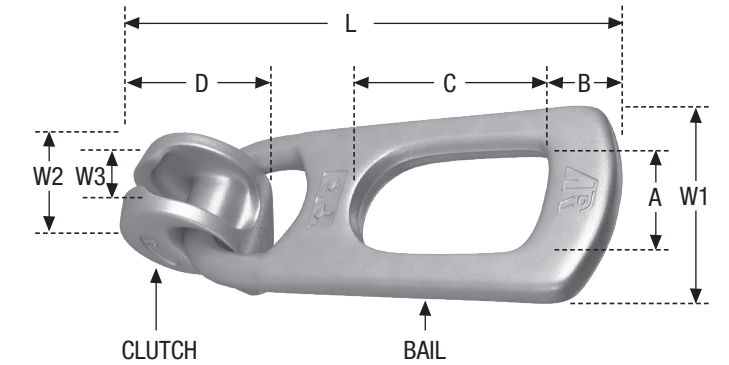

5:1 Approximate Safety Factor

Clutch Load Range (Tons)	Ultimate Tensile Load (Lbs)	Safe Working Load (Lbs)	Bail Dimensions										Body Dimensions					
			Length (L)		Width (W1)		A		B		C		Diameter (D)		Width (W2)		Slot Width (W3)	
			mm	in	mm	in	mm	in	mm	in	mm	in	mm	in	mm	in	mm	in
1.5T-2.5T	27,500	5,500	229	9"	89	3-1/2"	54	2-1/8"	25	1"	86	3-3/8"	65	2-9/16"	41	1-5/8"	17	11/16"
3T-5T	55,000	11,000	279	11"	117	4-5/8"	67	2-5/8"	38	1-1/2"	89	3-1/2"	86	3-3/8"	57	2-1/4"	22	7/8"
6T-10T	110,000	22,000	394	15-1/2"	159	6-1/4"	79	3-1/8"	51	2"	111	4-3/8"	114	4-1/2"	76	3"	32	1-1/4"

Ring Clutch

The AR Ring Clutch allows for a fully rotating bail. Engagement is quick, by simply rotating the curved bolt and dropping the clutch on the anchor and rotating the bolt back to the closed position. Ring Clutches are available from 2T to 10T load ratings. Refer to the following chart for further details.

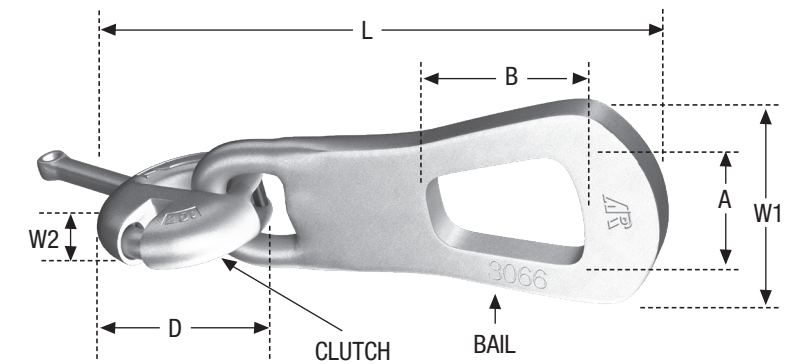

5:1 Approximate Safety Factor

Clutch Load Range (Tons)	Ultimate Tensile Load (Lbs)	Safe Working Load (Lbs)	Bail Dimensions								Body Dimensions			
			Length (L)		Width (W1)		A		B		Diameter (D)		Width (W2)	
			mm	in	mm	in	mm	in	mm	in	mm	in	mm	in
2T-3T	27,500	5,500	262	10-5/16"	95	3-3/4"	57	2-1/4"	83	3-1/4"	76	3"	29	1-1/8"
4T-6T	55,000	11,000	337	13-1/4"	117	4-5/8"	67	2-5/8"	114	4-1/2"	94	3-11/16"	37	1-7/16"
8T-10T	110,000	22,000	419	16-1/2"	149	5-7/8"	92	3-5/8"	137	5-3/8"	135	5-5/16"	51	2"

Quick Pin Chain Clutch

The AR Quick Pin Chain Clutch is similar to the standard AR Quick Pin Clutch, but uses chain links to allow the clutch to be loaded in any direction. Anchor capacity is stamped on the clutch for quick identification.

5:1 Approximate Safety Factor

Load Rating (Tons)	Ultimate Tensile Load (Lbs)	Safe Working Load (Lbs)	Length (L)	
			mm	in
2T	22,000	4,400	265	10-3/8"
4T	44,000	8,800	305	12"
8T	88,000	17,600	610	24"

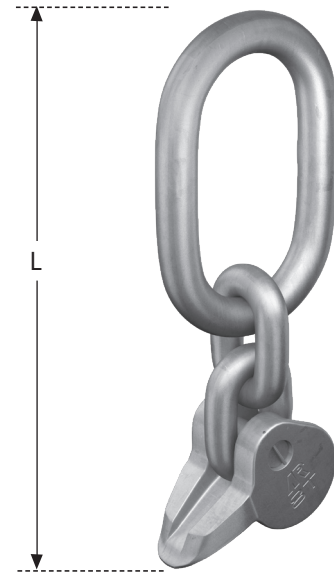

Void Formers

The AR Void Formers are made of a durable, heat and chemical resistant rubber, allowing them to be re-used. They are marked with the maximum load ratings and are colour coded for ease of identification.

Quick Pin Void Former

The Quick Pin Void Formers are available for 2.5, 5 and 8-ton applications, allow for a 90° anchor setting and place the anchor approximately 1/2" below the surface and come pre-assembled with a nut and stud for securing the anchor and void form.

Load Range (Tons)	Height (H)		Diameter (D)		Colour
	mm	in	mm	in	
2T-2.5T	38	1-1/2"	73	2-7/8"	Yellow
4T-5T	48	1-7/8"	95	3-3/4"	Blue
8T-10T	57	2-1/4"	117	4-5/8"	Yellow

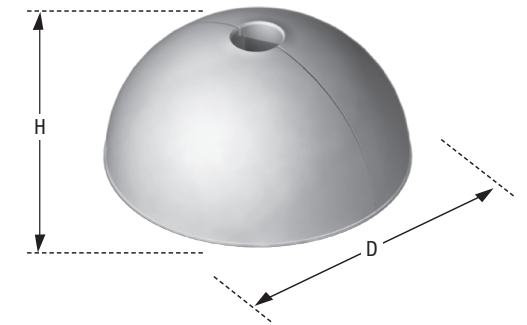

Utility Void Former

The Utility Void Formers allow for a 90° anchor setting and place the anchor approximately 1" below the surface. They are available in Regular and Large sizes and can be paired with a special holding plate for securing in the form.

Anchor Shaft Diameter	Length (L)		Height (H)		Width (W)		Anchor Orientation	Colour
	mm	in	mm	in	mm	in		
0.444"	248	9-3/4"	89	3-1/2"	76	3"	90°	Orange
0.671"	248	9-3/4"	89	3-1/2"	76	3"	90°	Black

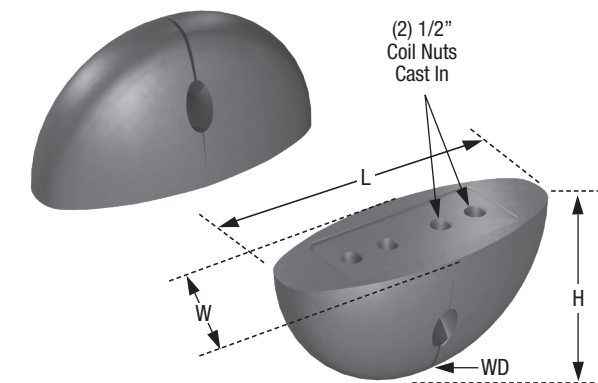
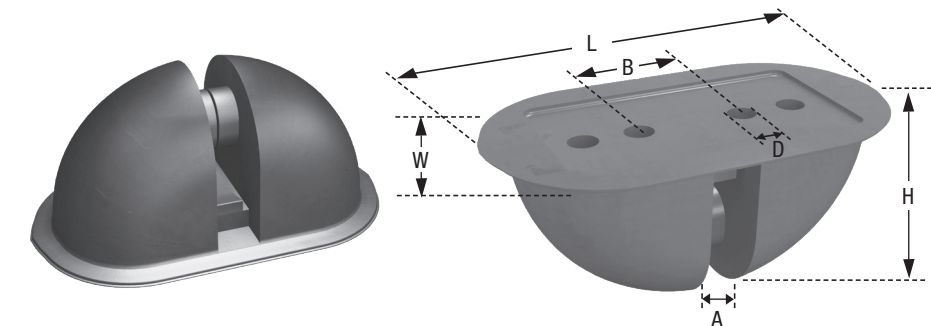

Plate Anchor Void Former

The AR Plate Anchor Void formers allow for a 90° anchor setting and place the anchor approximately 1" below the surface, providing clearance for the AR Ring Clutch to be used for lifting. Use the AR Holding Plate to secure in the form.



Load Range (Tons)	Length (L)		Height (H)		Width (W)		A		B		Diameter (D)		Colour
	mm	in	mm	in	mm	in	mm	in	mm	in	mm	in	
2T-2.5T	105	4-1/8"	44	1-3/4"	43	1-11/16"	10	3/8"	30	1-3/16"	10	3/8"	Orange
4T-5T	133	5-1/4"	59	2-5/16"	56	2-3/16"	16	5/8"	34	1-11/32"	10	3/8"	Black
8T-10T	188	7-13/32"	84	3-5/16"	79	3-1/8"	19	3/4"	50	1-31/32"	13	1/2"	Green

U-Anchor Void Former

The AR U-Anchor Void Former allows clearance for a regular lifting hook to be used. The formers can be secured to the form using two 1/2" x 2" lag bolts.

U-Anchor Size	Length (L)		Height (H)		Width (W)		Colour
	mm	in	mm	in	mm	in	
5/16"	157	6-3/16"	79	3-1/8"	121	4-3/4"	Light Green
3/8"	157	6-3/16"	79	3-1/8"	121	4-3/4"	Red
7/16"	157	6-3/16"	79	3-1/8"	121	4-3/4"	Light Blue

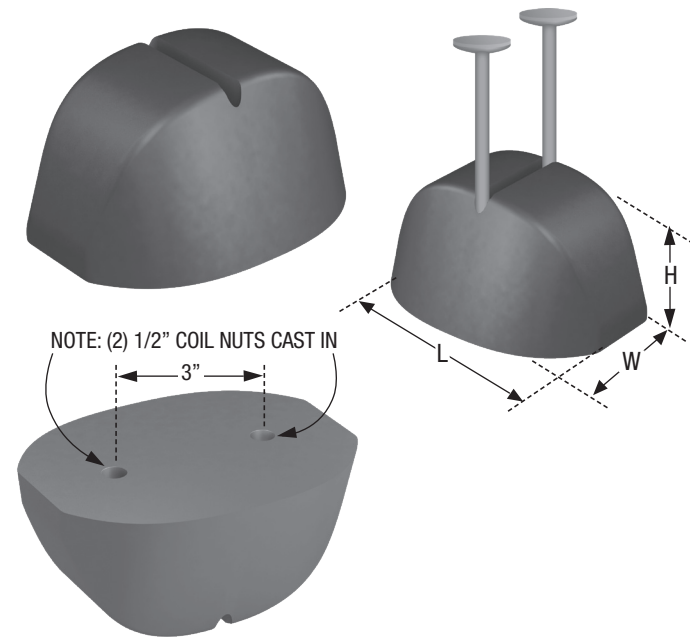

Double Head Quick Pin Void Former

The AR Double Head Quick Pin Void Formers are only to be used with AR Double Head Quick Pins. These void formers allow the both heads to sit in the former, and do not spread like the standard quick pin void former. The formers are fitted with a threaded nut on the back to allow for easy removal or to adjust anchor embedment height. Void formers are labelled with load rating for quick identification.

Load Range (Tons)	Height		Diameter		Embedment Depth		Thread Size
	mm	in	mm	in	mm	in	
1T	33	1-5/16"	60	2-3/8"	9	11/32"	M8
2T	43	1-11/16"	74	2-15/16"	11	7/16"	M10
4T	55	2-3/16"	94	3-11/16"	14	9/16"	M10



Holding Plate for Plate Anchor Void Former

The AR Holding Plates can be used with Utility and Plate Anchor Void Formers. The plates can be either nailed or screwed to forms to keep them in place. Alternatively, these plates can be used as a cap to prevent concrete from entering the former cavities.

Void Former Load Range (Tons)	Length (L)		Height (H)		Width (W)		Thickness (T)		Diameter (D)	
	mm	in	mm	in	mm	in	mm	in	mm	in
2T-2.5T	70	2-3/4"	24	15/16"	21	13/16"	4	5/32"	10	3/8"
4T-5T	86	3-3/8"	25	31/32"	30	1-3/16"	4	5/32"	10	3/8"
8T-10T	125	4-15/16"	40	1-19/32"	43	1-11/16"	4	5/32"	4	5/32"

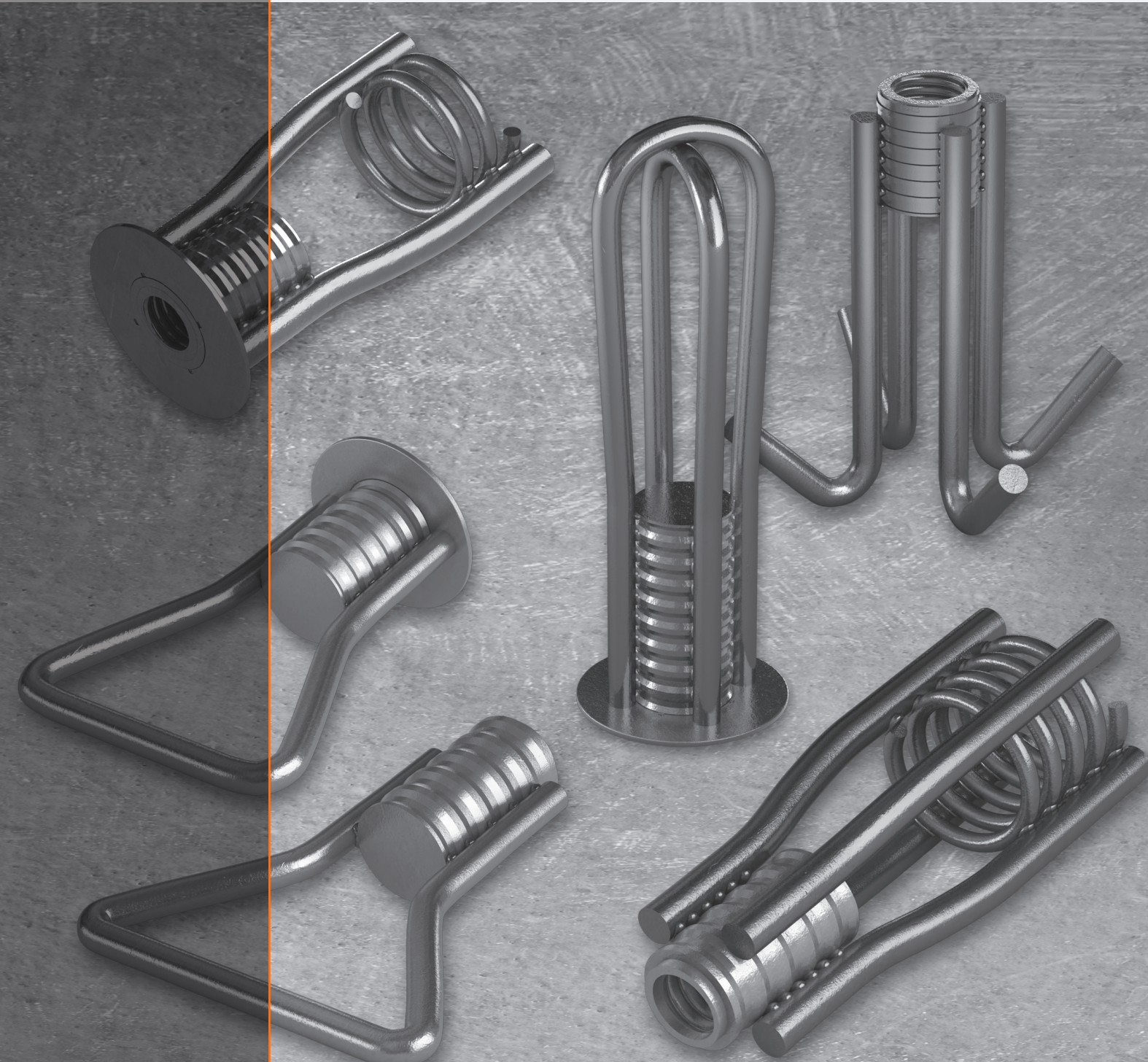
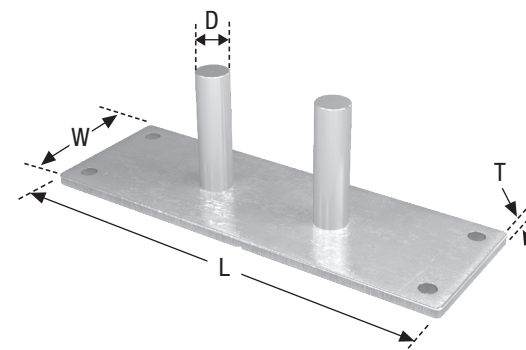

CONNECTING

Ferrule Concrete Inserts

AR Structural Connection Inserts are prefabricated from a special design which distributes the bolt stresses into the concrete for greater strength than any previously known device. Certified tests of these units in concrete at 20 MP (3000 psi) verify this claim and permit design engineers to approach the problem of fastening appurtenances to structural concrete with greater security than has been possible in the past. AR Structural Connection Inserts Type L, EC-2, EC-4 and EC-6 are furnished to engage the AR National Course Thread Rod (1/2"), (3/4"), (1") and (1 1/2"). Inserts mentioned above are also by the "F", i.e. LF, ECF-2. Open ferrules are supplied on order. All inserts can be supplied with a Flat Washer Base for nailing the insert to the sheathing or decking of the form, and are identified by the letter "W". i.e. LFW, ECF-2W. Inserts are supplied plain, or plated for corrosion resistance. A protective plating is available furnished on request. Above inserts can also be supplied in stainless steel.

SETTING

Type L, EC-2, EC-4 and EC-6 Inserts can be set with a template bolt. Template bolt provides clearance for final bolt without necessity of plug. Type LFW, ECF-2W, ECF-4W and ECF-6W have a flat washer base with nail holes for nailing or cementing to the forms and can be furnished with an Ethafoam filler to provide clearance for the final bolt. Removal of the Ethafoam filler clears the insert for engagement of the final holding bolt. Type LF, ECF-2, ECF-4 and ECF-6 Inserts can be set with a standard machine bolt, or Plastic Setting Plug.

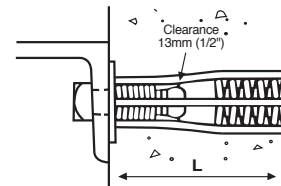

FINAL ANCHORAGE DETAIL

LF & LFW

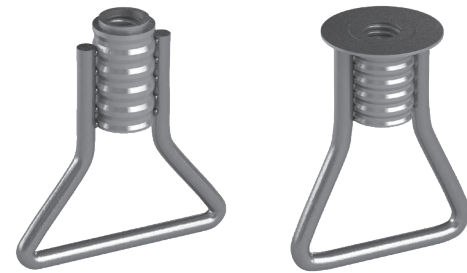

INSERT TYPE	DIA.	LENGTH inch (mm)	WIDTH inch (mm)	WASHER THICKNESS inch (mm)
LF	(3/8")	4 1/4" (108)	2 1/2" (60)	3/32" (2.38)
LF	(1/2")	4 1/4" (108)	2 1/2" (60)	3/32" (2.38)
LF	(3/4")	4 3/4" (121)	3" (70)	3/32" (2.38)

4:1 Approximate Safety Factor

BOLT DIAMETER AND SYMBOL	MIN. CONC. THICKNESS inch (mm)	INSERT LENGTH inch (L-mm)	INSERT WIDTH inch (O-mm)	WASHER THICKNESS inch (T-mm)	WORKING LOAD lbs (kN)	
					SHEAR	TENSION
3/8" Type LF	6" (150)	4 1/4" (108)	2 1/2" (60)	3/32" (2.38)	1,280 lbs. (5.7)	1,500 lbs. (6.65)
1/2" Type LF	6" (150)	4 3/4" (100)	2 1/2" (60)	3/32" (2.38)	1,500 lbs. (6.65)	1,500 lbs. (6.65)
5/8" Type LF	6" (150)	4 3/4" (121)	3" (70)	3/32" (2.38)	3,000 lbs. (13.35)	3,000 lbs. (13.65)
3/4" Type LF	6" (150)	4 3/4" (121)	3" (70)	3/32" (2.38)	3,525 lbs. (15.65)	3,375 lbs. (15.00)

*Also available 1" 4 Strut ECF - 4. NOTE: Ferrule type inserts are approximately 1/4 (6mm) longer than coil type inserts.

4:1 Approximate Safety Factor

TYPE LF INSERTS	FORCE IN kN (lbs) FOR EDGE DISTANCE - CENTERLINE OF INSERT TO NEAREST EDGE															
	1 1/2" (40mm)		2" (50mm)		3" (75mm)		4" (100mm)		5" (125mm)		6" (150mm)		8" (200mm)		9" (225mm)	
	TENSION	SHEAR	TENSION	SHEAR	TENSION	SHEAR	TENSION	SHEAR	TENSION	SHEAR	TENSION	SHEAR	TENSION	SHEAR	TENSION	SHEAR
1/2" Type LF	525 (2.30)	300 (1.30)	1,050 (4.60)	525 (2.30)	1,500* (6.60*)	900 (4.00)	1,200 (5.30)	1,500* (6.60*)							1,500* (6.60*)	1,500* (6.60*)
3/4" Type LF	750 (3.30)	375 (1.60)	1,500 (6.60)	600 (2.60)	2,250 (10.00)	975 (4.30)	3,000 (13.30)	1,350 (6.00)	3,375* (15.00)	2,250 (10.00)	3,525* (15.60*)				3,375* (15.00*)	3,525* (15.60*)

* Maximum insert load capacity. 20 Mpa concrete (3000 psi)

ECF-2 & ECF-2W

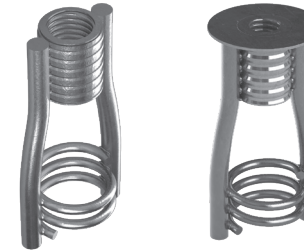

INSERT TYPE	DIA.	LENGTH inch (mm)	WIDTH inch (mm)	WASHER THICKNESS inch (mm)
ECF-2	(3/4")	4 3/4" (121)	2 1/4" (57)	1/8" (270)
ECF-2	(1")	5 3/4" (146)	2 5/8" (67)	3/16" (270)

BOLT DIAMETER AND SYMBOL	MIN. CONC. THICKNESS inch (mm)	INSERT LENGTH inch (L-mm)	INSERT WIDTH inch (O-mm)	WASHER THICKNESS inch (T-mm)	WORKING LOAD lbs (kN)	
					SHEAR	TENSION
3/4" 2 Strut Type 2ECF	6" (150)	4 3/4" (121)	2 1/4" (57)	1/8" (3.10)	3,525 lbs. (15.65)	4,500 lbs. (20.00)
*1" 2 Strut Type 2ECF	6" (150)	5 3/4" (146)	2 5/8" (67)	3/16" (4.70)	6,000 lbs. (26.70)	6,000 lbs. (26.70)

ECF-4 & ECF-4W

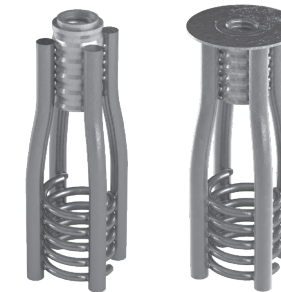

INSERT TYPE	DIA.	LENGTH inch (mm)	WIDTH inch (mm)	WASHER THICKNESS inch (mm)
ECF-4	(1")	5 3/4" (146)	2 5/8" (67)	3/16" (270)
ECF-4	(1 1/4")	7 5/8" (194)	3 1/4" (83)	7/32" (270)

BOLT DIAMETER AND SYMBOL	MIN. CONC. THICKNESS inch (mm)	INSERT LENGTH inch (L-mm)	INSERT WIDTH inch (O-mm)	WASHER THICKNESS inch (T-mm)	WORKING LOAD lbs (kN)	
					SHEAR	TENSION
1 1/4" 4 Strut Type 4ECF	8" (200)	7 5/8" (194)	3 1/4" (83)	7/32" (5.50)	9,000 lbs. (40.00)	12,000 lbs. (53.00)

ECF-6 & ECF-6W

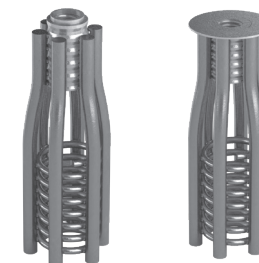

INSERT TYPE	DIA.	LENGTH inch (mm)	WIDTH inch (mm)	WASHER THICKNESS inch (mm)
ECF-6	(1 1/2")	9 1/2" (245)	4 3/8" (114)	7/32" (270)

BOLT DIAMETER AND SYMBOL	MIN. CONC. THICKNESS inch (mm)	INSERT LENGTH inch (L-mm)	INSERT WIDTH inch (O-mm)	WASHER THICKNESS inch (T-mm)	WORKING LOAD lbs (kN)	
					SHEAR	TENSION
1 1/2" 6 Strut Type 6ECF	12" (300)	9 1/2" (242)	4 3/8" (114)	7/32" (5.50)	12,000 lbs. (53.40)	18,000 lbs. (80.00)

LP-2F Connecting Inserts

The AR LP-2F Connecting Insert is manufactured with 1/2" and 3/4" (13 mm and 20 mm) diameter to engage AR lag thread bolts. Open or closed ferrules LP - 2F for use with 1/2" (M12), 5/8" (M16) and 3/4" (M20) diameter machine bolts are available as a connecting device or for special lifting conditions. Recommended for use in thin flat slabs where a high strength insert is not required.

4:1 Approximate Safety Factor

BOLT DIAMETER inch (mm) FERRULE	BASE inch (mm)	INSERT HEIGHT inch (mm)	MIN. CONC. THICKNESS inch (mm)	WORKING LOAD lbs (kN)	
				TENSION	SHEAR
(1/2)	4 3/4 (120)	2 1/2 (65)	3 (75)	900 (4.00)	1,610 (7.10)
(5/8)	170	2 1/2 (65)	3 (75)	940 (4.10)	2,700 (12.00)
(3/4)	7 (180)	3 1/2 (90)	4 (100)	2,000 (8.90)	2,850 (12.60)

20 MPa (3,000 psi) concrete. 4.1 Approximate Safety Factor (Ultimate: Dead Load) Working loads shown based on 230 mm (9") edge distance.

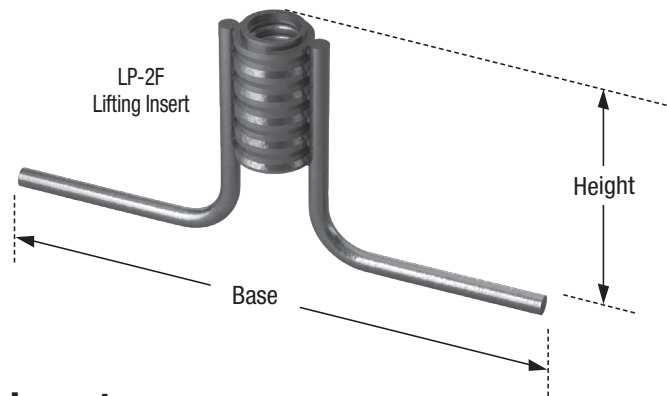

LP-4F Lifting Inserts

The AR LP-4 Connecting Insert is manufactured with 3/4", 1", 1 1/4", and 1 1/2" (20, 25, 32, and 38 mm) diameter coils to engage AR thread bolts. Open or closed ferrules LP - 4F for use with 3/4", 1", and 1 1/4" (20, 25, and 32 mm) size machine bolts are available as a connecting device or for special lifting conditions.

4:1 Approximate Safety Factor

BOLT DIAMETER inch (mm) FERRULE	BASE inch (mm)	INSERT HEIGHT inch (mm)	MIN. CONC. THICKNESS inch (mm)	WORKING LOAD lbs (kN)	
				TENSION	SHEAR
(1/2)	4 3/4 (120)	2 1/2 (65)	3 (75)	900 (4.00)	1,610 (7.10)
(5/8)	170	2 1/2 (65)	3 (75)	940 (4.10)	2,700 (12.00)
(3/4)	7 (180)	3 1/2 (90)	4 (100)	2,000 (8.90)	2,850 (12.60)

20 MPa (3,000 psi) concrete. 4.1 Approximate Safety Factor (Ultimate: Dead Load) Working loads shown based on 230 mm (9") edge distance.



*Note - Available with bent legs on request

Loop Insert (SLF)

The AR "SLF" (Loop Ferrule) type insert is especially suited for anchoring heating and air conditioning units, sprinkler systems, etc. The insert can be supplied with a Flat Washer Base (SLFW) for nailing or fixing the insert to the sheathing or decking of the form. The insert is supplied plain, or plated for corrosion resistance and can also be furnished in stainless steel. Available in four sizes to take 3/8", 1/2", 5/8" 3/4" and 1" standard machine bolt or threaded rod.

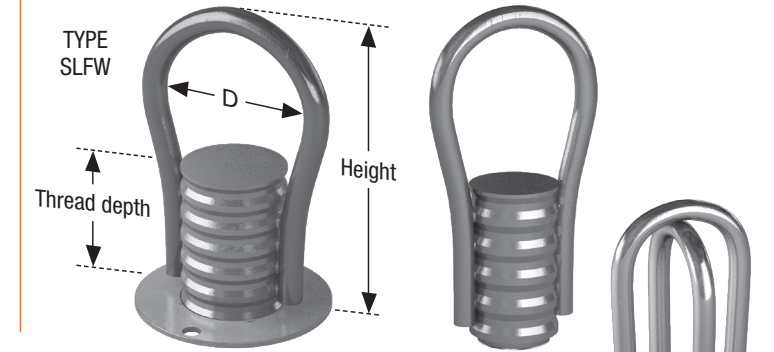

TYPE NUMBER inch (mm)	DIMENSION				SAFE WORKING LOAD lbs (kN)	TENSILE TEST IN 35 MPa CONCRETE 5000 PSI Concrete lbs (kN)	
	BOLT DIAMETER inch (mm)	THREAD DEPTH inch (mm)	"D" inch (mm)	HEIGHT H INCH (mm)		lbs	(kN)
SLF-3/8 (10)	(3/8) (10)	7/8 (22)	1 (25)	2 3/4 (70)	1,950 (8.6)	7,900 (35)	
SLF-1/2 (13)	(1/2) (13)	7/8 (22)	1 (25)	2 3/4 (70)	2,060 (9.1)	8,100 (36.2)	
SLF-5/8 (16)	(5/8) (16)	7/8 (22)	1 1/2 (38)	3 1/4 (85)	2,325 (10.3)	9,300 (41.4)	
SLF-3/4 (20)	(3/4) (20)	1 (25)	1 1/2 (38)	3 1/4 (85)	2,325 (10.3)	9,300 (41.4)	

* Also available 3/4" and 1" SLF-4W inserts
Contact your AR Sales Representative or the AR Technical Department for additional sizes and load information.

TYPE SLF-4W

Ferrule Diaphragm Loop (PFDL) and Re-bar Connector (PDR)

The Ferrule Diaphragm Loop and Re-bar Connector assembly is designed for use in tying prestressed concrete beams to the connecting diaphragm. The Ferrule Loop is set in the beam at the time of casting. After beam is set in place at bridge site, the Re-Bar Connector is threaded into the loop and laps the rebar in the diaphragm. Concrete diaphragm is then poured. Standard inserts are 3 1/2" (90 mm) long but Loop lengths can be manufactured to suit any job requirements. To order, give diameter and type by symbol and name.

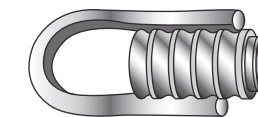
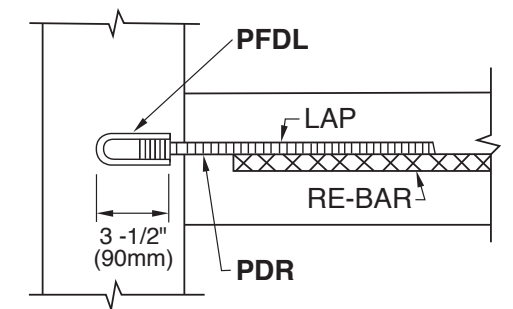

PFDL FERRULE DIAPHRAGM LOOP



RE-BAR CONNECTOR (PDR)

BOLT DIAMETER inch (mm)	PULL OUT SAFE LOAD* lbs (kN)
1/2 (13)	2,250 (10.0)
5/8 (16)	2,585 (11.5)
3/4 (20)	3,750 (16.7)
1 (25)	4,500 (20.0)

RE-BAR DESIGNATION	PDR THREAD LENGTH inch (mm)	PDR TOTAL LENGTH inch (mm)	YIELD	
			300 MPa BAR THREADED lbs (kN)	400 MPa BAR THREADED lbs (kN)
15M	1 3/8 (35)	18 7/8 (480)	6,000 (26.8)	8,000 (35.8)
20M	1 5/8 (40)	23 5/8 (600)	11,100 (49.5)	14,850 (66.0)
25M	1 5/8 (40)	23 5/8 (600)	17,500 (77.7)	23,300 (103.6)
25M	1 3/4 (45)	31 1/2 (800)	25,100 (112.0)	33,500 (149.3)

Hair Pin Type Inserts

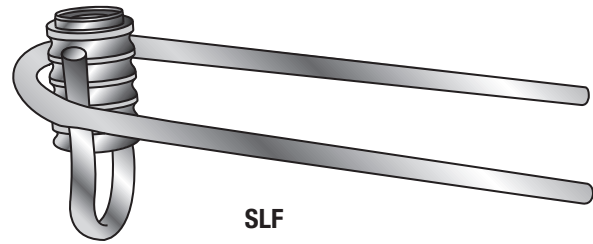

SLF

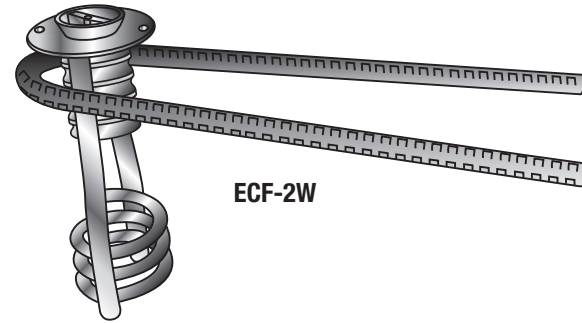

ECF-2W

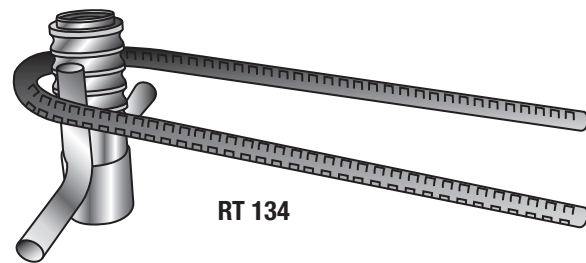

RT 134

4:1 Approximate Safety Factor

Bolt Size in	Description	Type	Height Insert in (mm)	Working Load lbs (kN)	TENSILE TEST IN 35 MPa CONCRETE 5000 psi (35MPa) lbs (kN)
3/4 Dia.	Structural Insert	SLF w/ Hairpin	3 1/4 (80)	2,760 (12.2)	8,300 (37)
3/4 Dia.	Structural Thru-Insert	RT 134 w/ Hairpin		Refer to page 31	
3/4 Dia.	Structural Insert	ECF-2W w/ Hairpin		Refer to page 27	

*All Product available with Nailing Washer on Request

AR Thru-Insert (RT 134)

With standard or nail-on type AR "THRU-INSERTS" Field Erectors can now use one size bolt for connections. The AR THRU-INSERT is designed to allow for bolt adjustment to cope with field tolerances. The standard THRU-INSERT for 3/4" (M20) dia. bolt with 2" (50 mm) adjustment is 3" (75 mm) deep. The THRU-INSERT can be furnished for large adjustment on request.

ULTIMATE TENSILE STRENGTH BY ACTUAL TEST IN CONCRETE SLABS

RT-134(W) Thru-Insert	CONCRETE ST RENGTH 3750 PSI (2 5 MPa)	lbs (kN)	
		#1	#2
4" (100 mm) Slab	Reinforcing Under Legs	#1	8,940 (39.70) Ultimate
		#2	9,860 (43.80) Ultimate
	No Reinforcing	#1	7,700 (34.30) Ultimate
		#2	7,380 (32.50) Ultimate
6" (150 mm) Slab	Reinforcing Under Legs	#1	8,900 (39.60) Ultimate
		#2	8,840 (39.30) Ultimate
	No Reinforcing	#1	8,300 (36.90) Ultimate
		#2	7,600 (33.80) Ultimate

Note: clearance in thru-insert for bolt adjustment

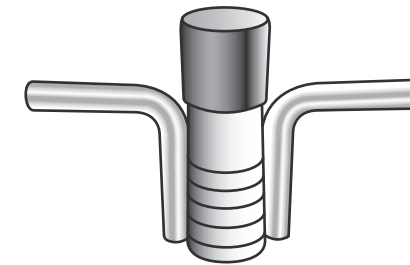

STANDARD THRU-INSERT
TYPE RT 134

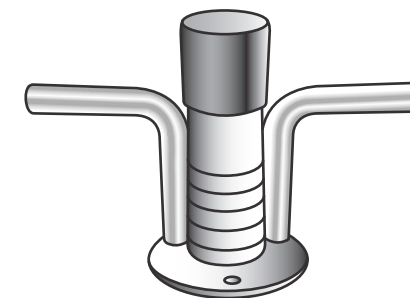
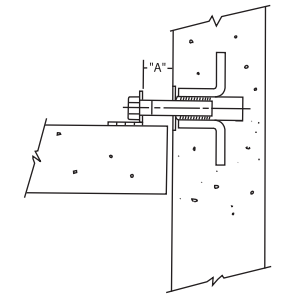
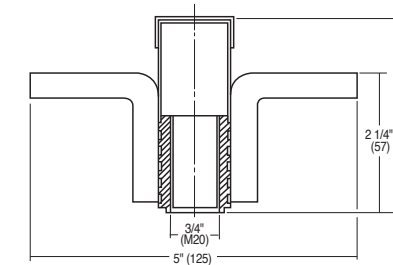

STANDARD THRU-INSERT
TYPE RT 134 W

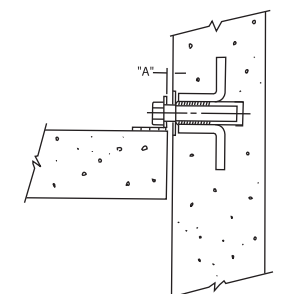
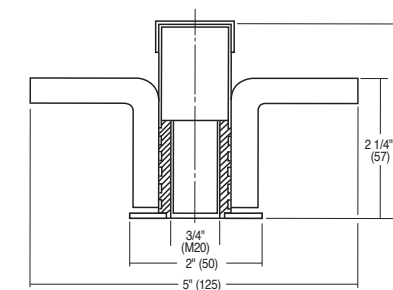

Thin Slab Ferrule Insert (ITBF & ITSF)

The AR Thin Slab Ferrule Inserts are designed to develop better working loads in very thin slab. The inserts are designed to take machine thread studs or bolts and can be set with Plastics Setting Plug. They can also be furnished with a flat washer base for nailing to the forms. Available in 3/8", 1/2", 5/8", 3/4", 1" diameter.

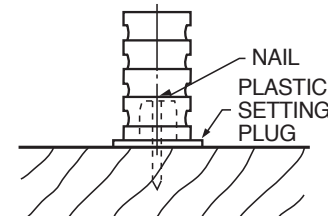

Ferrule type set by means plastic plug

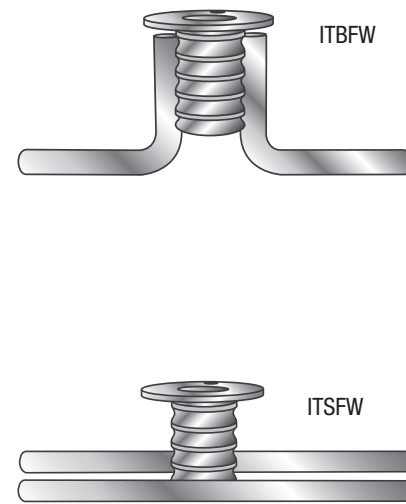
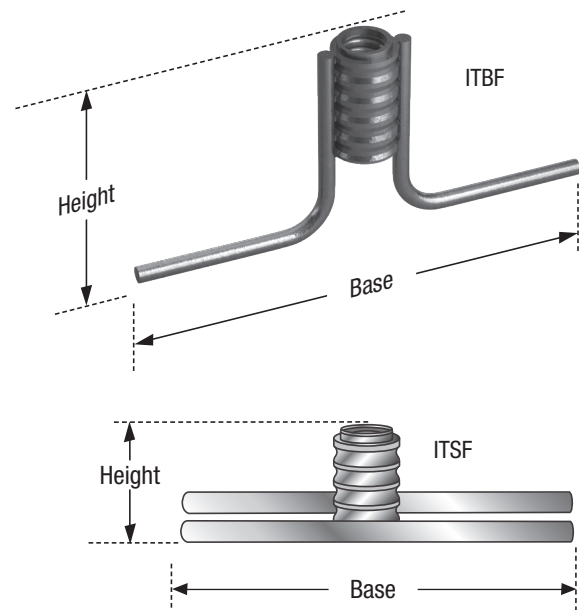

3:1 Approximate Safety Factor

FERRULE INSERT

TYPE	SIZE (dia. of bolt)	MIN. CONCRETE THICKNESS	THREAD inch (mm)		WORKING LOADS* lbs (kN)		TENSILE TEST IN 3000 psi Conc. (20 MPa)	
			H	L	TENSION	SHEAR	lbs	kN
ITBF	3/8"	4" (100)	2 1/8" (55)	5" (130)	6.19 (1,390)	7.10 (1,600)	4,175	(18.6)
	1/2"	4" (100)	2 1/8" (55)	5" (130)	6.90 (1,560)	9.70 (2,200)	4,700	(20.9)
	5/8"	4" (100)	2 1/8" (55)	5" (130)	7.00 (1,580)	16.00 (3,600)	4,750	(21.1)
	3/4"	4" (100)	2 1/8" (55)	5" (130)	7.40 (1,670)	16.90 (3,800)	5,000	(22.2)
	1"	4" (100)	3" (75)	7" (180)	10.20 (2,300)	20.00 (4,500)	6,900	(30.6)
ITSF	3/8"	3" (75)	1 3/8" (35)	4" (100)	3.50 (800)	6.00 (1,350)	2,400	(10.7)
	1/2"	3" (75)	1 3/8" (35)	4" (100)	5.30 (1,200)	9.55 (2,150)	3,600	(16.0)
	5/8"	3" (75)	1 1/2" (38)	6" (100)	5.50 (1,250)	16.00 (3,600)	3,660	(16.3)
	3/4"	3" (75)	1 5/8" (42)	6" (100)	6.00 (1,350)	16.80 (3,800)	3,800	(16.9)
	1"	4" (100)	1 3/4" (48)	6" (150)	9.30 (2,100)	17.80 (4,000)	6,300	(27.9)

*All Product available with Nailing Washer on Request

Plain Ferrule Insert (IPF & IPFW)

The AR Plain Ferrule Insert is an economical steel insert designed to take imperial thread studs or bolts. Manufactured on 3/8", 1/2", 5/8", 3/4", 7/8", 1", and 1 1/4" (10 mm, 13 mm, 16 mm, 20 mm, 25 mm, and 32 mm) diameter. To order, specify IPF or IPFW Plain Ferrule insert and diameter.

5:1 Approximate Safety Factor

PLAIN FERRULE INSERT (IPF)

BOLT DIAMETER	DIM. H inch (mm)	THREAD DEPTH inch (mm)	MIN. CONCRETE THICKNESS inch (mm)	WORKING LOADS lbs (kN)	
				SHEAR	TENSION
3/8"	1 3/8" (35)	7/8" (22)	3" (75)	800 (3.5)	200 (.90)
1/2"	1 3/8" (35)	7/8" (22)	3" (75)	1,000 (4.4)	650 (2.80)
5/8"	1 1/2" (38)	7/8" (22)	3" (75)	1,250 (5.5)	700 (3.10)
3/4"	1 5/8" (42)	1" (25)	4" (100)	1,600 (7.0)	850 (3.80)
7/8"	1 3/4" (45)	1 1/8" (29)	6" (150)	2,000 (8.9)	1,150 (3.80)
1"	1 7/8" (48)	1 1/4" (32)	6" (150)	2,300 (10.1)	1,250 (5.50)
1 1/4"	2" (52)	1 3/8" (35)	6" (150)	3,000 (13.2)	1,700 (7.50)

Safe working load figures are based on test in 20 MPa concrete blocks and safe working loads shown are for a 5.1 Approximate Safety Factor. NOT TO BE USED FOR LIFTING PURPOSES.

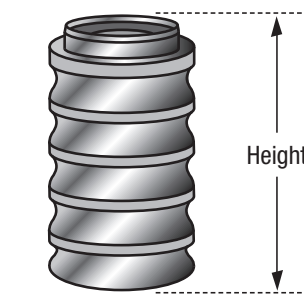

IPF
PLAIN FERRULE INSERT

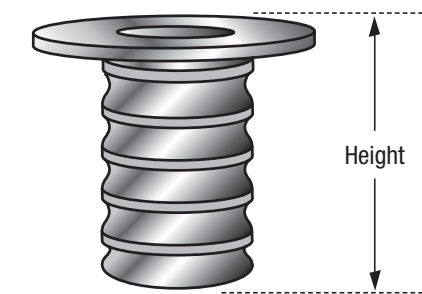

IPFW
PLAIN FERRULE INSERT
WITH NAILING WASHER

NC Zinc Precast Threaded Insert

Ideal for use in precast units and poured-in-place concrete structures where fastener locations can be precisely planned. Made of rustproof zamac alloy to prevent surface staining. Install with bolts through holes in steel forms or by means of reusable concrete insert plugs on wood forms.

NUMBER	LENGTH in (mm)	THREAD SIZE in (mm)
PZI-25	1 3/8" (35)	1 3/8" (35)
PZI-35	1 1/2" (40)	1 1/2" (40)
PZI-36	2 7/8" (73)	2 7/8" (73)

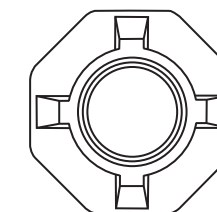

Askew Head Bolts

The Askew Head Bolt is designed to prevent any possibility of slippage when the nut is drawn up tight. Askew Head Bolts should be used with all wedge type inserts shown. Supplied with 3/4" thread in 1 1/2", 2", 1 1/2" and 3" (40 mm, 50 mm, 65 mm & 75 mm) lengths. Do not use "bumped" or standard machine bolts which could cause slippage and failure.

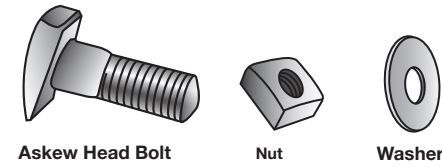

Peerless Wedge Insert

The Peerless Wedge Shelf Angle Insert is a malleable iron casting with a wedge shaped holding face which works in conjunction with a special askew head bolt. Designed to hold a shelf angle at an exact elevation for masonry veneer support, this wedge action prevents any possibility of slippage when the nut is drawn up tight. The casting is provided with nailing lugs and sufficient holes for nailing to the form. The anchor loop has adequate shape to accept reinforcing bar to assist anchorage.

BOLT DIAMETER AND INSERT TYPE	MIN. EDGE DISTANCE in (mm)	APPLIED WORKING LOAD lb (kN)
M20 STD. PEERLESS WEDGE	2 7/8 (73)	2,600 lbs. (11.60)
M20 LINTEL ANCHOR WEDGE	2 3/8 (60)	1,800 lbs. (8.00)

Safe working loads shown reflect a 4:1 approximate safety factor, (ultimate: applied working load) for concrete compressive strength of 4000 psi (30 MPa).

When cast metal inserts are specified it is suggested that safety factors appropriate to service and usage criteria be applied. An approximate safety factor of 4:1 is recommended

Note: Working load capacity is with load applied at 2" (50 mm) from face of insert as shown

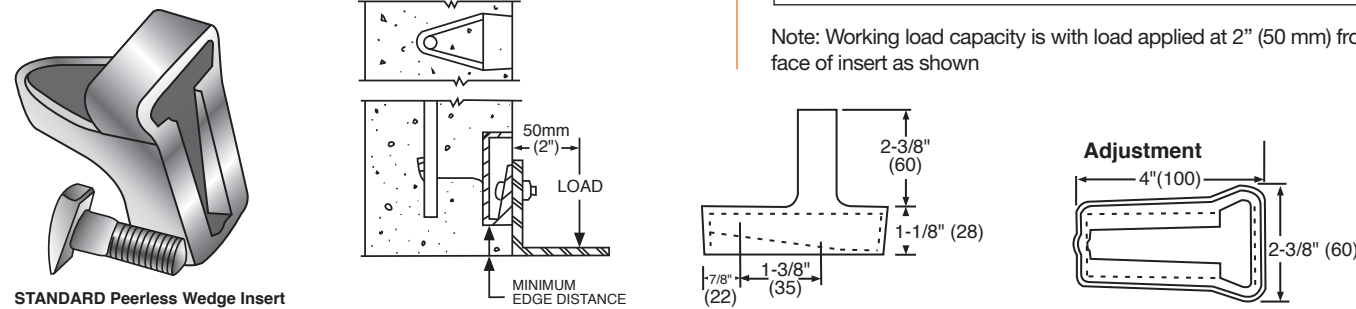

Lintel Anchor Wedge Insert

The Lintel Anchor Insert is a malleable iron casting with a wedge shaped holding face which works in conjunction with a Standard askew head bolt. The Anchor loop is specially designed to allow for clearance of I-Beam Flanges as illustrated. Manufactured for 3/4" dia. askew head bolt only.

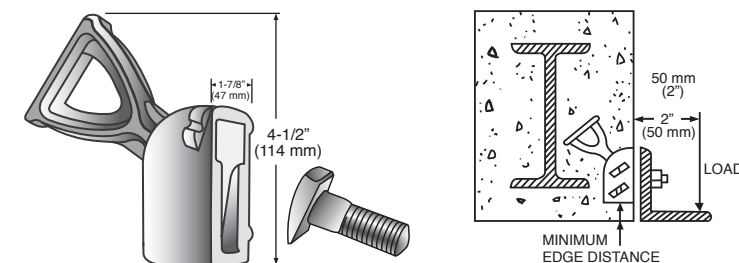

TO DETERMINE "P" WHERE DIMENSION HH VARIES, USE FORMULA

$$\frac{8.0 \text{ kN} \times 50 \text{ mm}}{\text{HH mm}} = P \text{ (kN)} \leq 8.0 \text{ kN Max.}$$

TO DETERMINE "P" WHERE DIMENSION HV VARIES, USE FORMULA

$$\frac{8.0 \text{ kN} \times \text{HV mm}}{56 \text{ mm}} = P \text{ (kN)} \leq 8.0 \text{ kN Max.}$$

TO DETERMINE "P" WHERE CONCRETE STRENGTH VARIES, USE FORMULA

$$\frac{(\text{HV mm})}{(\text{HH mm})} \times 8.0 \text{ kN} \sqrt{\frac{F_{\text{conc}}}{30 \text{ MPa}}} = P \text{ (kN)} \leq 8.0 \text{ kN Max.}$$

Continuous Slotted Insert

Concrete inserts installed in reinforced concrete provide a continuous slot for the precise location of hanger rods or frames. Install concrete inserts across the anticipated area of use and save time and money by eliminating the necessity of drilling holes for anchors. Use in wall, floors and ceiling. All inserts are complete with two anchor caps and styrofoam filler. This filler resists the entrance of wet concrete but is easily removable. Supplied in lengths up to 20'6 m (6 m).

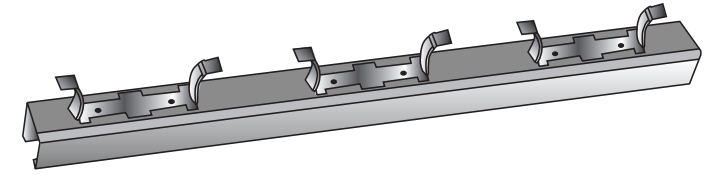

Turnbuckle

The turnbuckle allows prefabricated concrete parts to be connected without any additional materials or resources. Without any need to comply with cure times, the connection can immediately bear a full load and thus generates significant time and cost savings in comparison to other established systems. Available in 12 mm, 16 mm & 20 mm.



Formsavers™

AR Formsaver™ dowel bar assemblies provide continuity and structural integrity to reinforced concrete construction in segmental pour applications. The AR Formsaver™ is designed with our unique tapered thread system, factory installed thread protectors, and durable mounting plates for easy attachment to forms. The taper threaded design, like the complete family of couplers, provides load path continuity in tension, compression and stress reversal applications. AR Formsaver™ mechanical splices provide superior performance well beyond the yield strength of the reinforcing bar.

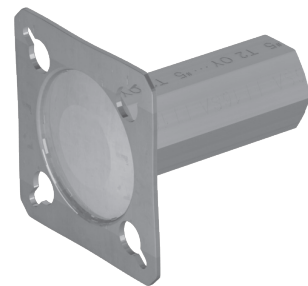

REBAR DESIGNATION				Taper Threaded Rebar (Male) ¹			Coupler/Rebar Assembly (Female) ²			
ASTM in-lbs	mm	Type	Soft Metric	Part Number	Length "C"		Part Number	Length "D"		
					mm	(in)		mm	(in)	
4	12 m	10 M	13 mm	FS4M24	610 mm	(24")	FS4F20	508 mm	(20")	
				FS4M36	914 mm	(36")	FS4F24	610 mm	(24")	
5	16 mm	15 M	16 mm	FS5M24	610 mm	(24")	FS5F24	610 mm	(24")	
				FS5M30	762 mm	(30")	FS5F30	762 mm	(30")	
				FS5M36	914 mm	(36")	FS5F36	914 mm	(36")	
6	20 mm	20 M	19 mm	FS6M36	914 mm	(36")	FS6F24	610 mm	(24")	
							FS6F36	914 mm	(36")	
7	22 mm	—	22 mm	FS7M36	914 mm	(36")	FS7F36	914 mm	(36")	
				FS7M48	1219 mm	(48")				
8	25 mm	25 M	25 mm	FS8M48	1219 mm	(48")	FS8F52	1321 mm	(52")	
9	28 mm	30 M	29 mm	FS9M48	1219 mm	(48")	FS9F52	1321 mm	(52")	
10	32 m	-	32 mm	FS10M60	1524 mm	(60")	FS10F64	1626 mm	(64")	
11	36 mm	35 M	36 mm	FS11M60	1524 mm	(60")	FS11F64	1626 mm	(64")	

¹ Includes Rebar Thread Protector

² Includes Coupler Thread Protector

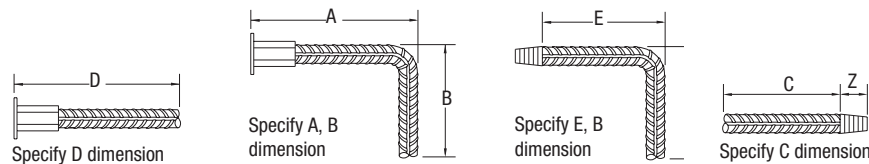

How to Order by Part Number

FS	SIZE	STYLE	LENGTH	X	LENGTH	E
Attached nailer plate form saver	Rebar size	F indicates coupler/rebar, M indicates threaded rebar (other styles on request)	In mm (inches) of "A", "C" or "D"	Indicates bent rebar (optional)	In mm (inches) of "B" (optional)	Epoxy (optional)

Non standard custom sizes and lengths available.

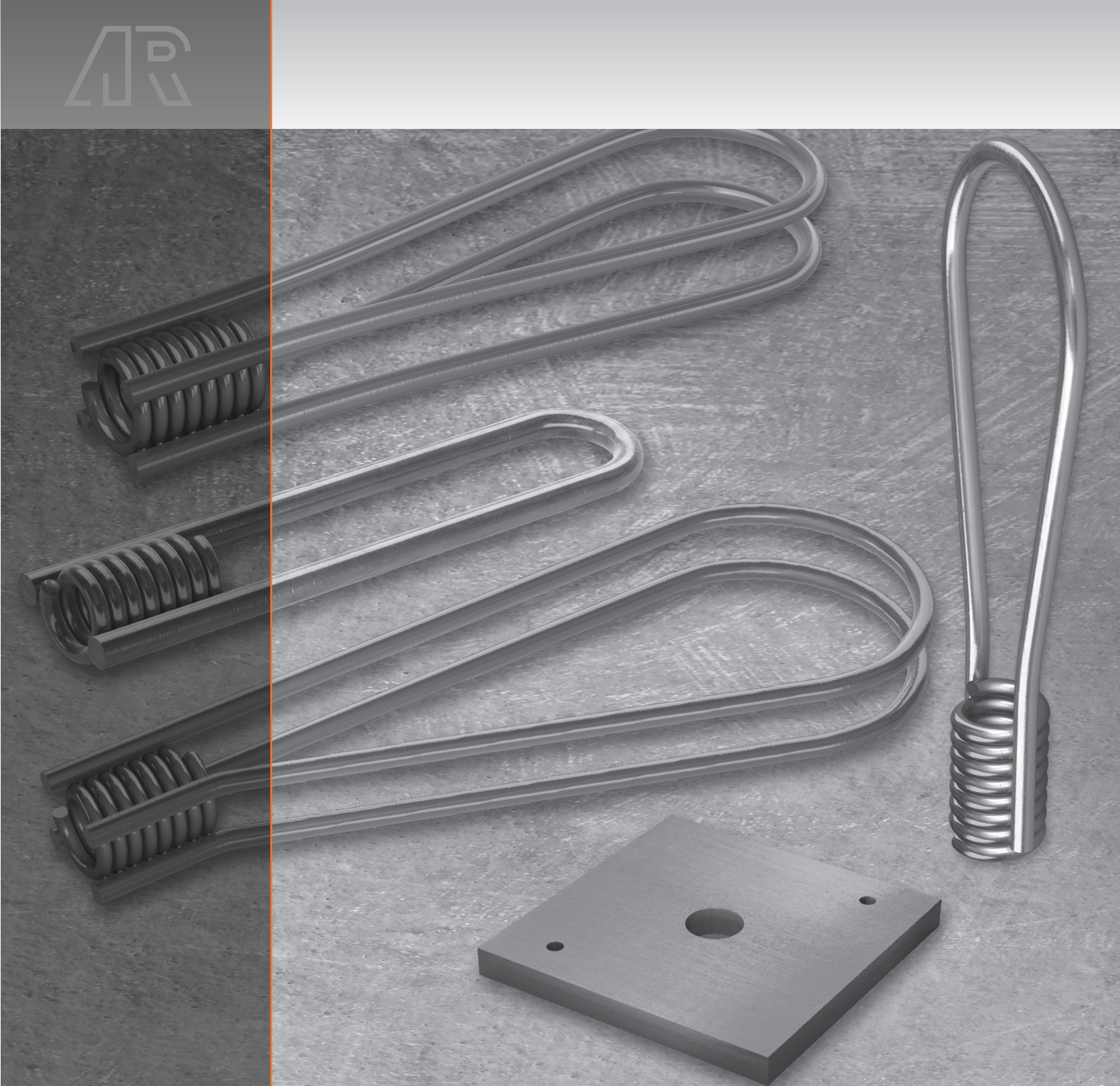
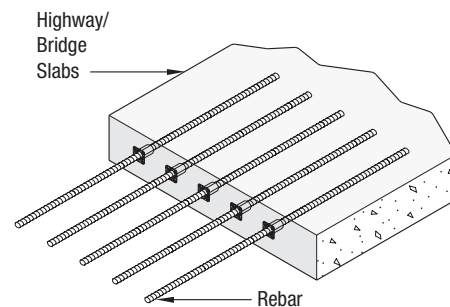
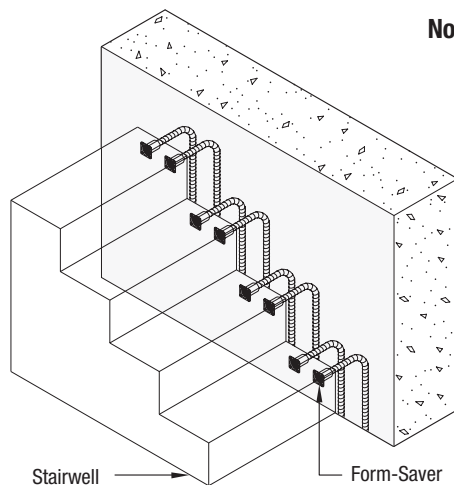

FORMING

Lag/Coil Connecting Inserts

AR 2-strut and 4-strut Tyloops are made with looped wire welded to a coil, suitable for light to heavy form anchorage in concrete construction. Tyloops are made straight, flared, offset flared depending on the requirement.

Standard 2-Strut Tyloop (TL2)

AR 2 Strut Tyloops are made of a single looped wire welded to a coil in 1/2" (13 mm) and 3/4" (20 mm) nominal diameters. Suitable for light anchorage requirements or as emergency Tie, Tie Down, Corner Tie, etc. Standard length is, 4" (100 mm) for 1/2" (13 mm) diameter. Can be fabricated in lengths to suit job.

To order, give nominal diameter, by length, symbol and name. Example: - 1/2" x 4" (13 mm x 100 mm) TL2 Tyloop.

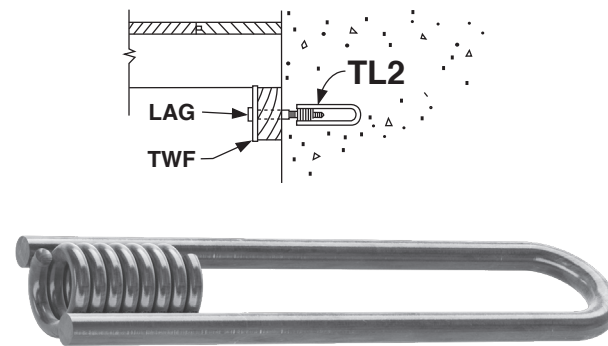

Heavy 2-Strut Tyloop (TL2-H)

AR 2 Strut Heavy Tyloops are made the same as the Standard Tyloops but with heavier wire. Principally used as anchors for medium heavy construction. Standard length is 6" (150 mm) for 3/4" (20 mm) diam. Can also be fabricated in longer length if required.

To order, give nominal diameter, by length, symbol and name. Example: - 3/4" x 6" (20 mm x 150 mm) TL2-H Heavy Tyloop.

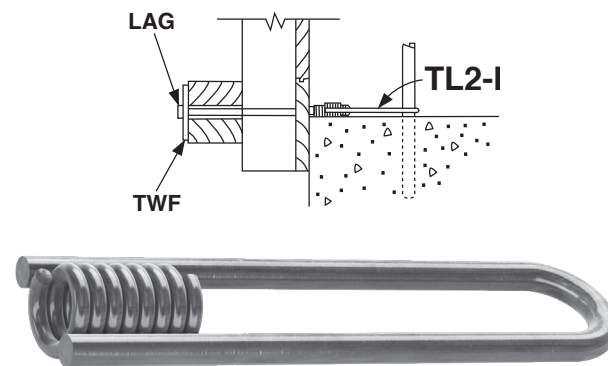

Flared 2-Strut Tyloop (TL2F)

AR 2 Strut Flared Tyloops are made with the loop end flared for greater anchorage in the concrete. Standard lengths are 9" (230 mm) for 1/2" (13 mm) diameter and 12" (305 mm) for 3/4" (20 mm) diameter. Can be supplied in special lengths and flares To order.

To order, give nominal diameter, by length, symbol and name. Example: - 1/2" x 9" (13 mm x 230 mm) TL2F 2 Strut Flared Tyloop.

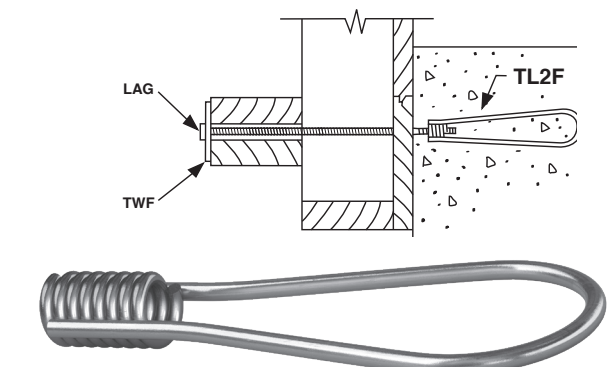

Flared 4-Strut Tyloop (TL4)

AR 4 Strut Flared Tyloops are made with two looped wires welded to a coil. Suitable for heavy form anchorage in mass concrete construction. Standard length for 1" or 1 1/4" (25 mm or 32 mm) nominal diameter coil and 3" (76 mm) flare. Other sizes available. Supplied straight unless outward flares are requested.

To order, give nominal diameter, by length, symbol and name. Example: - 1" x 12" (25 mm x 300mm) TL4F 4 Strut Flared Tyloop.

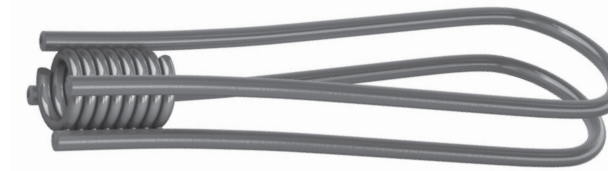
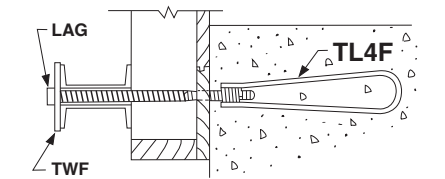

Sizes	
inch	(mm)
1/2" - 6"	(13 - 150)
3/4" - 9"	(20 - 225)
1" - 12"	(25 - 300)
1 1/4" - 15"	(32 - 380)

Heavy 4-Strut Offset Flared Tyloop (TL4-H)

AR 4 Strut Offset Flared Tyloops are made of two looped wires welded to a coil. The loops are flared and offset so that the centre of anchorage is below the centre line of the coil to distribute the load well into the concrete and still keep the coil at or near the top of the pour or other boundary restrictions.

To order, give nominal diameter, by length, symbol and name. Example: 1 1/4" x 30" (32 mm x 760 mm) (TLO4F) offset Flared Tyloop.

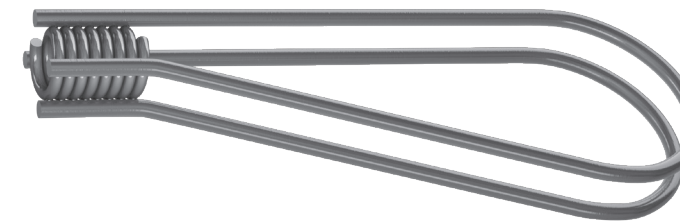
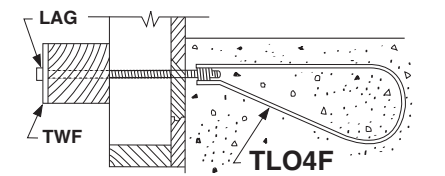

Sizes	
inch	(mm)
1 x 15	(25 x 380)
1 1/4 x 18	(32 x 460)

Other sizes available

4:1 Approximate Safety Factor

APPROXIMATE WORKING LOADS FOR TYLOOPS

Size and Type	* As Tie	As an Anchor**			
		Tension	Shear***	Tension	Shear***
inch (mm)	lbs (kN)	lbs (kN)	lbs (kN)	lbs (kN)	lbs (kN)
TL2 1/2" x 4" Standard Tyloop (13 x 100)	1,900 (8.5)	1,125 (5.0)	750 (3.5)		
TL2 3/4" x 6" Standard Tyloop (20 x 150)	3,900 (17.5)	2,250 (10.0)	1,500 (7.0)		
TL2-H 3/4" x 6" Heavy Tyloop (20 x 150)	5,200 (23.0)	2,625 (12.5)	1,875 (8.3)		
TL2F 1/2" x 9" Flared Tyloop (13 x 230)	—	2,250 (10.0)	750 (3.5)		
TL2F 3/4" x 12" Flared Tyloop (20 x 305)	—	3,375 (15.0)	1,875 (8.3)		
TL4F 1" x 15" Flared 4-Strut (25 x 380)	—	6,000 (26.5)	3,375 (15.0)		
TL4F 1 1/4" x 15" Flared 4-Strut (32 x 380)	—	6,750 (30.0)	4,500 (20.0)		

* As a tie around a dowel. ** 3000 psi (20 MPa) concrete. *** Shear ratings specified are for mass concrete, not thin wall precast sections.

Heavy Hex Rod Coupler

AR Heavy Hex Rod Couplers are used to couple two High Tensile Inside Rods of the same diameter. The Coupler is normally supplied with National Course (NC) thread and is available with lag thread on request. Standard sizes are shown and other sizes are available on request.

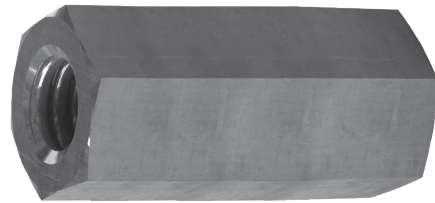

2:1 Approximate Safety Factor

Rod Diameter in (mm)	Overall Length in (mm)	Safe Working Load lbs (kN)
1/2 (13)	1 3/4 (45)	4,500 (20)
5/8 (16)	2 1/4 (57)	7,500 (33.5)
3/4 (20)	2 1/4 (57)	9,000 (40)
7/8 (22)	2 1/2 (64)	15,000 (67.5)
1 (25)	2 3/4 (70)	18,750 (84.5)

Lag Thread Coupler

AR Lag Thread Couplers are used to couple two Lag Rods of the same diameter. The Lag Thread Coupler is used with lag thread systems and is manufactured with a positive stop.

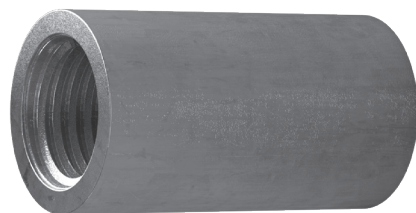

2:1 Approximate Safety Factor

Rod Diameter in (mm)	Outside Diameter in (mm)	Overall Length in (mm)	Type m	Safe Working Load lbs (kN)
1/2 (13)	3/4 (20)	2 (50)	9	9,000 (40)
3/4* (20)	1 1/8 (30)	3 (75)	18	18,000 (80)
1* (25)	1 1/2 (38)	4 (100)	37.5	37,500 (167)

*Also available with UN Thread: 3/4" - 10 UN - 1 1/4" Dia. x 2" Long / 1" - 8 UNC - 1 1/2" Dia. x 2 1/2" Long

Flat Washer

AR Flat Washers are made from flat steel plate. For optimization, AR Washers are square. For best results the washer should be placed so that its length runs parallel to the walers and the gap or space spanned by the washer should not exceed the physical bolt diameter plus 1/4" (6 mm).

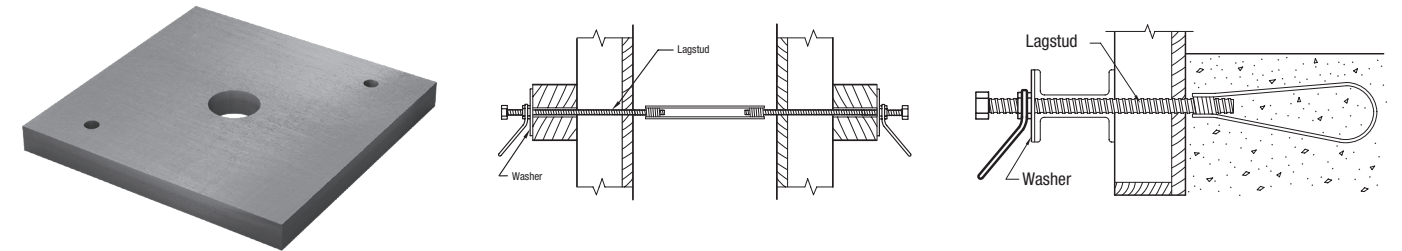

Bolt Diameter in (mm)	Plate Size in (mm)	Hole Size in (mm)
1/2 (13)	3 3/4 x 3 3/4 x 1/4 (95 x 95 x 6)	9/16" (14 mm)
3/4 (20)	5 x 5 x 3/8 (125 x 125 x 10)	13/16" (21 mm)
3/4 (20)	6 x 6 x 1/2 (150 x 150 x 13)	13/16" (21 mm)
1 (25)	5 x 5 x 3/8 (150 x 150 x 10)	1 1/16" (27 mm)
1 (25)	6 x 6 x 1/2 (150 x 150 x 13)	1 1/16" (27 mm)
1 1/4 (32)	6 x 6 x 1/2 (150 x 150 x 13)	1 3/8" (35 mm)
1 1/4 (32)	8 x 8 x 3/4 (200 x 200 x 19)	1 3/8" (35 mm)
1 1/2 (38)	Contact AR Technical Department for details.	

Bolt Dia.	Plate Size	DISTANCE BETWEEN WALER									
		1"	1 1/4"	1 1/2"	1 3/4"	2"	2 1/4"	2 1/2"	2 3/4"	3"	3 1/4"
1/2"	3 3/4" x 3 3/4" x 1/4"	6,750 lbs	3,750 lbs	2,500 lbs	1,900 lbs	1,600 lbs		1,100 lbs			
3/4"	5" x 5" x 3/8"	25,000 lbs	14,000 lbs	9,000 lbs	7,000 lbs	5,600 lbs		4,000 lbs			
3/4"	6" x 6" x 1/2"	60,000 lbs	33,000 lbs	22,000 lbs	16,000 lbs	13,500 lbs		9,600 lbs			
1"	5" x 5" x 3/8"		38,000 lbs	38,000 lbs	24,000 lbs	18,000 lbs	14,000 lbs		10,000 lbs		
1"	6" x 6" x 1/2"		38,000 lbs	38,000 lbs	24,000 lbs	18,000 lbs	14,000 lbs		10,000 lbs		
1 1/4"	6" x 6" x 1/2"			37,000 lbs	37,000 lbs	27,000 lbs	19,000 lbs	15,000 lbs			
1 1/4"	8" x 8" x 3/4"			125,000 lbs	125,000 lbs	91,000 lbs	65,000 lbs	50,000 lbs			10,000 lbs
1 1/2"	Contact AR Technical Department for details.										

Bolt Size	Plate Diameter (mm)	DISTANCE BETWEEN WALER									
		25 mm	32 mm	35 mm	45 mm	50 mm	57 mm	63 mm	70 mm	75 mm	82 mm
13	95 x 95 x 6	30 kN	16 kN	11 kN	8.5 kN	7.1 kN		4.9 kN			
20	125 x 125 x 10		111 kN	62 kN	40 kN	31 kN	25 kN		18 kN		
20	150 x 150 x 13		266 kN	146 kN	98 kN	71 kN	60 kN		43 kN		
25	125 x 125 x 10			169 kN	169 kN	106 kN	80 kN	62 kN		45 kN	
25	150 x 150 x 13			169 kN	169 kN	106 kN	80 kN	62 kN		45 kN	
32	150 x 150 x 13				165 kN	165 kN	120 kN	85 kN	66 kN		45 kN
32	200 x 200 x 19				555 kN	555 kN	405 kN	290 kN	220 kN		155 kN
38	Contact AR Technical Department for details.										

System load reduction from increased waler spacing.

Magfly “AP” Magnet

MAGFLY AP is a high performance magnet with an aluminium casing and an integrated adapter for MultiForm and FlyFrame shuttering systems, the new system magnet has come along as both a real powerhouse and a lightweight. With a magnetic force of 22,000 N and a weight of only 5.40 kg it has the best magnetic force to weight ratio of its class worldwide.

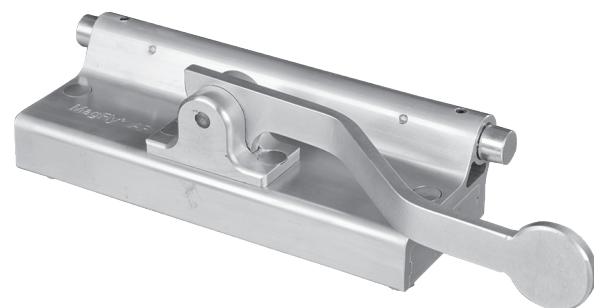

Magnet GB

The GB MAGNET is used for fixing threaded sleeves, pigtail anchors etc., on both horizontal and vertical surfaces. It is available with different diameters and magnetic forces. Available in 50, 64, 80, 106.

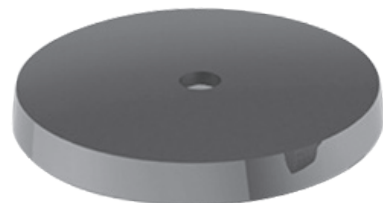

Multiform Bracket

With MULTIFORM you can simplify your shuttering construction. The front of the shuttering support can be covered with a facing in wood, chipboard, plastic or steel. This is screwed into place from the back. In this way the formwork facing remains undamaged and indentations in the concrete produced by screw heads are a thing of the past. And with facing concrete, this means that time-consuming filling and sanding is no longer necessary. Available in 90 mm, 148 mm, 190 mm, 248 mm, 290 mm, 390 mm heights.

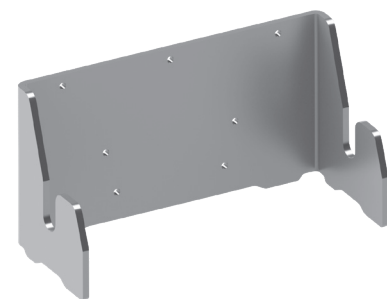

Multiformwork Inside Corner H

The MULTIFORM inside corner is a high-quality robust shuttering element for example in doors and windows of the elements. With MULTIFORM you can simplify your shuttering construction. The front of the shuttering support can be covered with a facing in wood, chipboard, plastic or steel. This is screwed into place from the back. In this way the formwork facing remains undamaged and indentations in the concrete produced by screw heads are a thing of the past. And with facing concrete, this means that time-consuming filling and sanding is no longer necessary. Available in 98 mm, 148 mm, 248 mm, 298 mm, 348 mm, 398 mm heights.

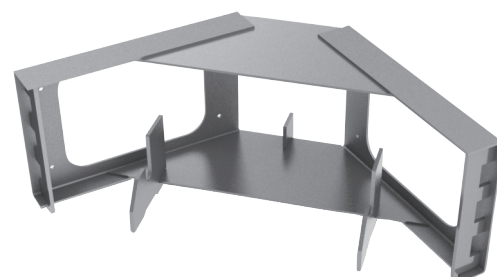

Multiform Type 2

With MULTIFORM you can simplify your shuttering construction. The front of the shuttering support can be covered with a facing in wood, chipboard, plastic or steel. This is screwed into place from the back. In this way the formwork facing remains undamaged and indentations in the concrete produced by screw heads are a thing of the past. And with facing concrete, this means that time-consuming filling and sanding is no longer necessary. Available in 98 mm, 148 mm, 198 mm, 248 mm, 298 mm, 348 mm, 398 mm, 448 mm, and 98 mm heights with an overall length of 3025 mm.

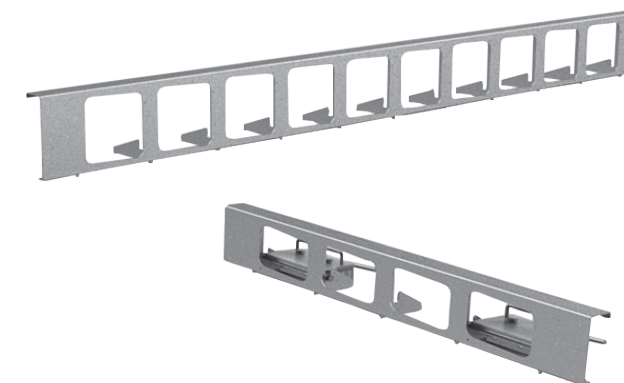

Precast Angle Hanger

Precast Angle Half Hanger is designed to be cast into the top of a concrete girder and subsequently support the formwork. Available for 1/2" (13 mm) fastener at 90°, 45° and 15° angles.

FASTENER DIA.	ANGLE	RATE	SAFE WORKING LOAD	
1/2" Bolts	15°	STD	3,500 lb	15.6 kN
1/2" Bolts	15°	HD	6,000 lb	26.7 kN
1/2" Bolts	45°	STD	4,500 lb	20.1 kN
1/2" Bolts	45°	HD	6,000 lb	26.7 kN
1/2" Bolts	90°	STD	3,500 lb	15.5 kN
1/2" Bolts	90°	HD	6,000 lb	26.7 kN

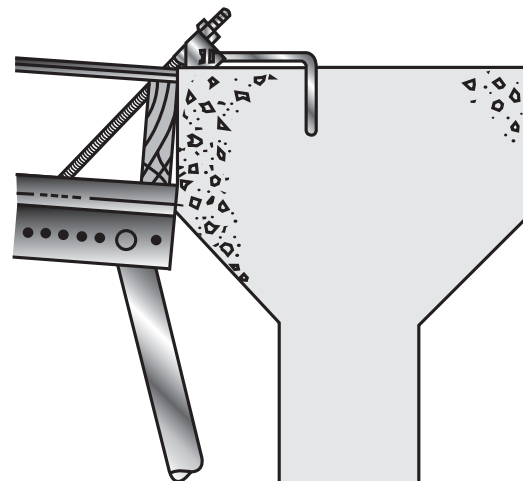
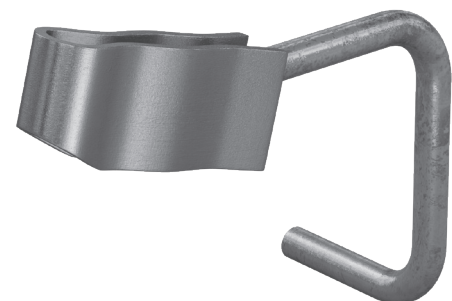
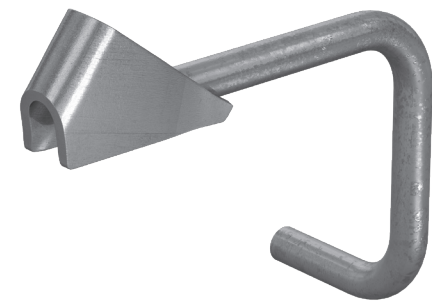
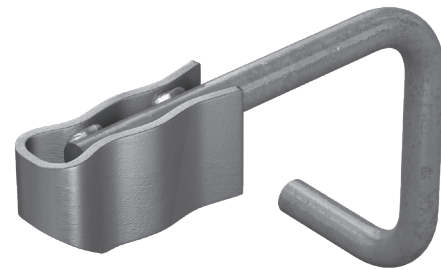

ACCESSORIES

Continuous Threaded Lagstud

The AR Continuous Threaded Lagstud is perhaps the most versatile of all the members of the AR Tyscru family. This versatile product can be used in combination with the complete line of Tyscru products. Continuous Threaded Lagstud is available in both mild steel and high tensile in 12' (3.6 m) lengths. Field cutting may be accomplished with bolt cutters or carborundum blades.

Other lengths available on request.

The Lagstud is particularly adaptable in combination with Tyscrus to make adjustable Tys, embedded in concrete or rock as an adjustable anchorage for the Tyscru, or in combination with Handle Lagnuts as an emergency lagstud bolt.

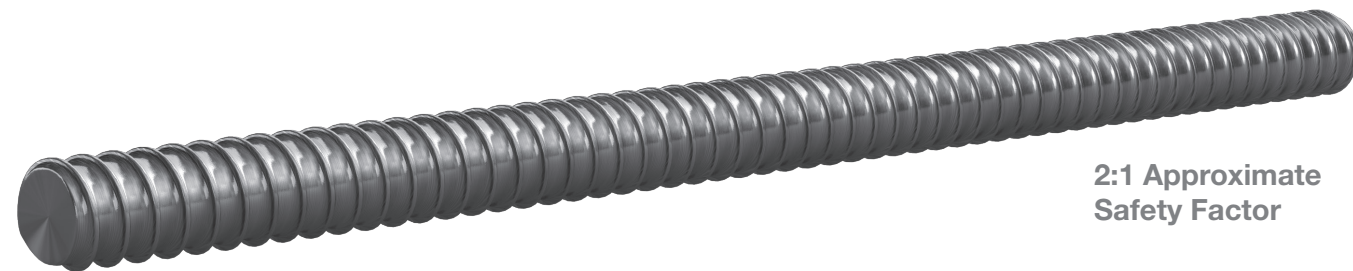

2:1 Approximate
Safety Factor

LAGSTUD TENSILE PROPERTIES

Diameter in (mm)	Mild Steel		High Tensile Steel			
	Ultimate Loads lbs (kN)	Safe Working Loads lbs (kN)	Ultimate lbs	Loads (kN)	Safe Working lbs	Loads (kN)
½ (13)	15,000 (70)	7,000 (33)	18,000 (80)	9,000 (40)		
¾ (20)			36,000 (160)	18,000 (80)		
1 (25)	50,000 (220)	25,000 (110)	75,000 (335)	37,500 (165)		
1¼ (32)	74,000 (330)	37,000 (165)	120,000 (530)	49,000* (216)*		
1½ (38)	Contact the AR Technical Department for details.					

*When using 1¼" (32 mm) High Tensile Lagstud, use double nuts to obtain full capacity of Rod, 60,000 lbs (265 kN).

LAGSTUD FOR EMBEDDED ANCHORS

Diameter in (mm)	Approx. Safe Working Loads @ 2:1		Embedment "H"			
	lbs	(kN)	1,000 psi (6.9 MPa) in (mm)		2,000 psi (13.8 MPa) in (mm)	
½ (13)	4,500	(20)	16	(408)	12	(304)
½ (13)	6,750	(30)	20	(508)	15	(378)
¾ (20)	9,000	(40)	24	(609)	18	(458)
1 (25)	13,500	(60)	32	(816)	24	(609)
1 (25)	18,000	(80)	40	(1,020)	30	(760)
1¼ (32)	27,000	(120)	40	(1,020)	30	(760)

Continuous Threaded Lagstud

STRENGTH OF LAGSTUD

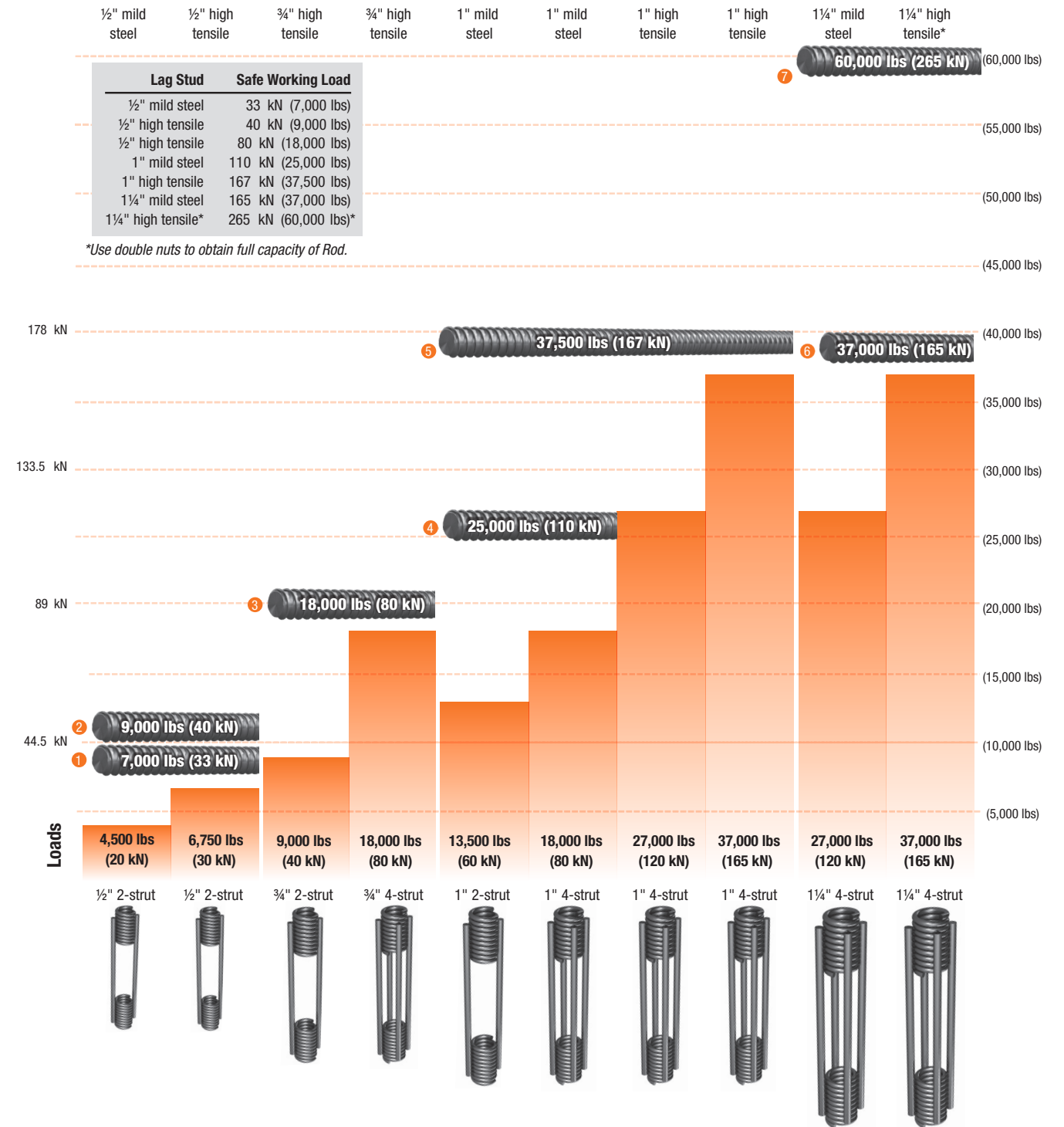

Lagstud Bolt

AR Lagstud Bolts are threaded for the coil of an AR Tyscru or insert. Available in 1/2", 3/4", 1" and 1 1/4" (13 mm, 20 mm, 25 mm and 32 mm) diameters and lengths as required in 2" (50 mm) increments. All Lagstud Bolts have a hexagon nut welded to it as an integral head and should be used with a running nut, handle lagnut or wingnut as shown

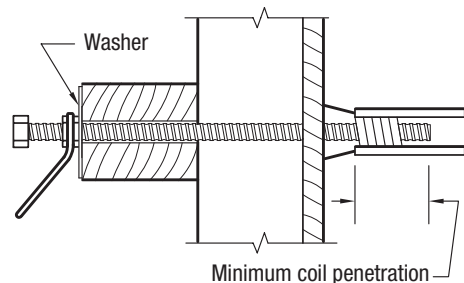

2:1 Approximate Safety Factor

Diameter in (mm)	Mild Steel		High Tensile	
	lbs	(kN)	lbs	(kN)
1/2 (13)	7,000	(33)	9,000	(40)
3/4 (20)	N/A	N/A	18,000	(80)
1 (25)	25,000	(110)	37,500	(165)
1 1/4 (32)	37,500	(165)	49,000*	(216)
1 1/2 (38)	Contact the AR Technical Department for details.			

*When using 1 1/4" (32 mm) High Tensile Lagstud, use double nuts to obtain full capacity of Rod, 60,000 lbs (265 kN).

All lagstud bolts must be used with running nut, handle lagnuts or wing nuts.

Handle Lagnut

AR Handle Lagnuts are made of hex nuts welded to substantial wire loops. Available in 1/2", 3/4", 1" and 1 1/4" (13 mm, 20 mm, 25 mm and 32 mm) diameters with lag thread. The handle eliminates the need for using a wrench and makes installation and/or stripping fast and simple.



2:1 Approximate Safety Factor

Bolt Diameter in (mm)	Threads per inch (TPI)	Handle length from nut centre in (mm)	Safe Working Load lbs (kN)
1/2 (13)	6	5 (125)	9,000 (40)
3/4 (20)	4 1/2	4 7/8 (120)	18,000 (80)
1 (25)	3 1/2	5 1/2 (140)	37,500 (167)
1 1/4 (32)	3 1/2	8 3/8 (210)	57,500 (256)
1 1/2 (38)	Contact the AR Technical Department for details.		

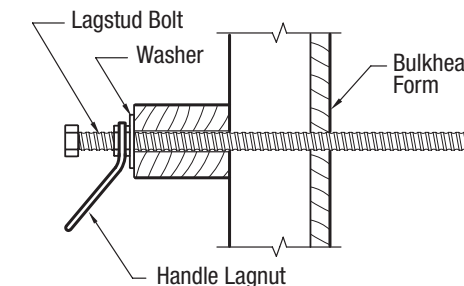

Lagnut

AR Lagnuts are manufactured with Lag thread and are available in 1/2" through 1 1/2" (13 mm through 38 mm) diameters.

Warning: when utilizing Lagnuts on through-Ty applications, such as Continuous Threaded Lagstud, double nuts are required to develop ultimate loads for 1 1/4" (32 mm) applications. For all other applications, AR Lagnuts are designed to develop the full published ultimate load of AR Lagstud.

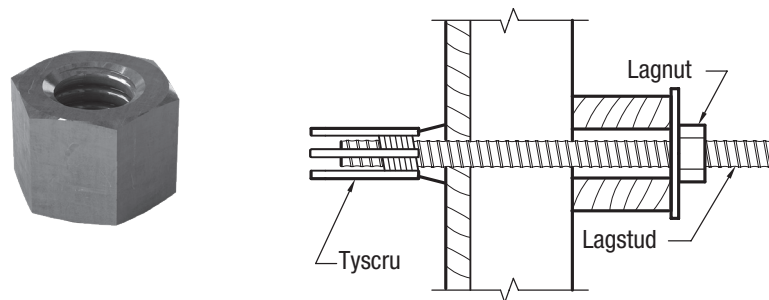

2:1 Approximate Safety Factor

Diameter in (mm)	APPROX. SAFE WORKING LOADS	
	lbs	(kN)
1/2 (13)	9,000	(40)
3/4 (20)	18,000	(80)
1 (25)	37,500	(167)
1 1/4 (32)	49,000*	(216)*
1 1/2 (38)	AR Technical Department for details.	

*When using 1 1/4" (32 mm) High Tensile Lagstud, use double nuts to obtain full capacity of Rod, 60,000 lbs (265 kN).

Wingnut

AR Wing Nuts are manufactured with a lag thread and are used with AR She-Bolts or Taper-Tys. Fabricated in 20 mm, 25 mm and 32 mm (3/4", 1" and 1 1/4") diameters.

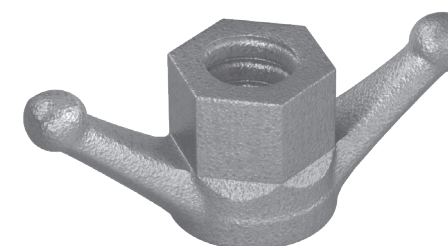

Size in (mm)	Ultimate Tensile Load lbs (kN)
3/4 (20)	40,000 (178)
1 (25)	82,000 (365)
1 1/4 (32)	115,000 (512)

To order, please specify the following information

EXAMPLE
Name Wing Nut
Quantity 25 mm (1")

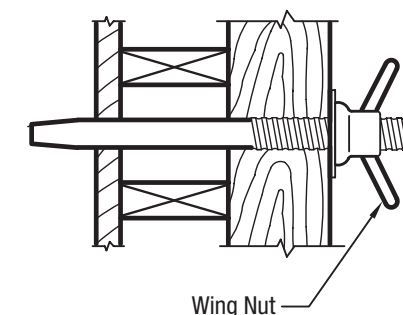

Single Line Strand Deflection Insert with Rollers (SPD)

The Single Line Standard Deflection Insert (SPD) is available in 3/4", 1", and 1 1/4" diameters and is designed to deflect 1/2" (13 mm) Strands in a single vertical line. FOR STRAND SPACING, SAFE LOADS AND OTHER INFORMATION SEE CHART BELOW.



Strand Deflection Insert with Rollers

The Strand Deflection Insert are designed to deflect 3 rows of 1/2" (13 mm) Strands in a vertical line. For strand spacing, safe loads and other information see chart.

2:1 Approximate Safety Factor

For All Strand Deflection

BOLT DIA. (in)	**MAX. SWL PER STRAND lbs (kN)	SAFETY WORKING LOAD -approx 2:1 F.O.S.				STRAND SPACING HORIZ. x VERT. in (mm)
		SPD lbs (kN)	SSSD lbs	D-SSSD (kN)		
3/4"	4,500 (20)	12,000 (54)	19,000	(85)	2 x 2 (50 x 50)	
1"	4,500 (20)	22,250 (100)			2 x 2 (50 x 50)	
1 1/4"	4,500 (20)	36,000 (160)			2 1/4 x 2 (57 x 50)	

**Max. Unit Safe Load shall not be exceeded. All Safe Loads are based on 2:1 Approximate Safety Factor. Safe Loads can only be developed using high strength bolts (GR5). The arm distance from bottom of insert to centre line of first strand is a minimum standard of 2" (50 mm).

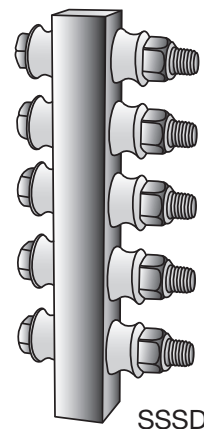

SSSD

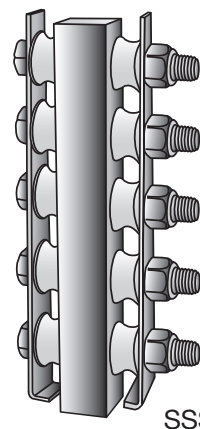

SSSD with retainer

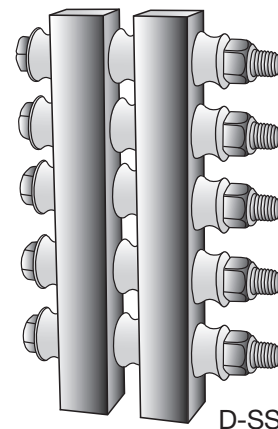

D-SSSD

Note: Tube Type Strand Deflection Inserts available as special order. Contact AR technical department for other spacing and strand diameter requirements.

Plastic Setting Plugs

The AR Plastics Plug has a centre hole for nailing to wood forms. The centre hole can also be tapped for fastening the plug to steel forms. The Plastic Cap Plug is ideal for sealing inserts cast in place to prevent the entry of dirt, water, etc. when not in use. Available in 1/4", 3/8", 1/2", 5/8", 3/4", 7/8" and 1" (10 mm, 13 mm, 16 mm, 20 mm, 22 mm and 25 mm) diameter.

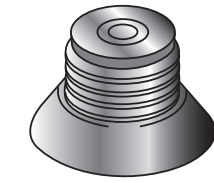

Plastic Setting Plug

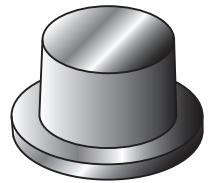

Plastic Cap Plug



LEP Ethafoam Plug

Plastic Coil Setting Plug

AR Plastic Coil Setting Plugs are available from 1/2" to 1 1/4" (13 mm to 32 mm) diameters for the AR Tyscrus System. The Plastic Coil Setting Plugs are easy to fasten to the inside face of form ply using the pre-drilled nail holes. Once secured, the AR Tyscrus can be threaded in place.

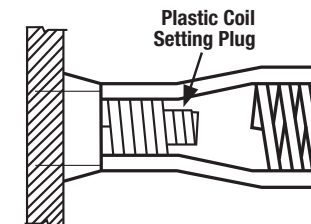
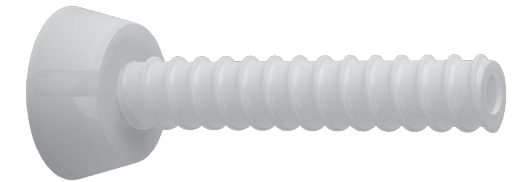

Setting EC Type Insert by means of Plastic Coil Setting Plug nailed to Forms

Polyserts - Plastic Fixing Blocks

POLYSERTS are the ideal fixing points in concrete, precast concrete and terrazzo for installation of: Window and door frames, Door jambs, Curtain tracks, Ceiling and wall strapping. Polyserts are distinctively colour coded and easily located when form work has been removed. Being made of inert polyethylene, they protect the shanks of wood and lag screws or nails from the damaging corrosion effects of alkali. Drilling of pilot holes of the appropriate size facilitates screw entry.

COLOUR CODE	TEST DATA			DESCRIPTION	ULTIMATE LOAD lbs (kN)
	L in (mm)	W in (mm)	H in (mm)		
YELLOW	1 (25)	3/4 (20)	1 (25)	1" (25 mm) deep tested with #10 screw	750 (3.30)
GREEN	1 (25)	3/4 (20)	1 1/2 (38)	1 1/2" (38 mm) deep tested with #10 screw	1250 (5.50)
BLUE	2 (50)	3/4 (20)	1 (25)		
RED	2 (50)	3/4 (20)	1 1/2 (38)		

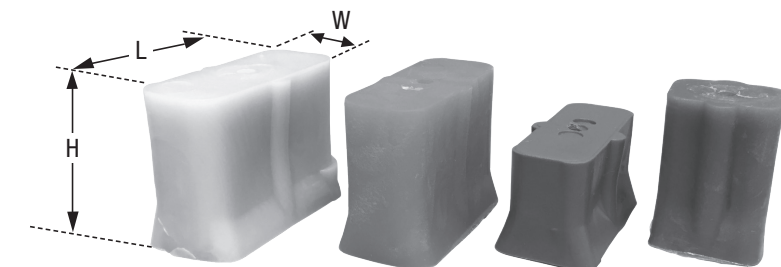

Bubble Spacers

Bubble Spacers were developed for the precast industry for use as spreader cleats between precast panels. They are available in sizes 2" x 2", 3" x 6" (50 mm x 50 mm and 75 mm x 150 mm) and are designed to take the following compression.

	SIZE in (mm)		COMPRESSION STRENGTH lbs (kn)
BS1	2 x 2	(50 x 50)	40,000 (178)
BS2	3 x 6	(75 x 150)	40,000 (178)
BS3	3 x 6	(75 x 150)	40,000 (178)

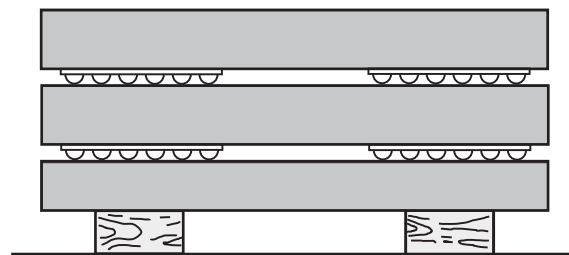

Manhole Steps

Manhole steps (also referred to as ladder rungs) are used to form a ladder necessary to access underground sewer and utility structures. The AR ladder rungs are Grade 60 steel reinforced steps wrapped with polypropylene plastic, feature a non-slip tread and are available in black or orange, single face or double face, in a variety of step widths. All steps meet or exceed applicable ASTM, AASHTO and OSHA requirements. Supporting accessories such as inserts, magnetic locators and cam pins are also available.



Reinforcing Bar Supports

Reinforcing Bar Supports are used to support and space reinforcing steel. AR Bar Supports are manufactured according to specifications published by the Concrete Reinforcing Steel Institute. To eliminate rust spots or similar blemishes on the concrete surface specify AR's Plastic Bar Supports.

(SB) Slab Bolster

Used for supporting lower slab steel from slab form. Corrugations spaced 1" (25 mm) on centres serve as guides for spacing bars. Legs are spaced 5" (127 mm) on centre. Stocked in 3/4", 1", 1 1/2", 2" (20, 25, 38 and 50 mm) in heights in 5' (1525 mm) lengths.



(PSB) Slab Bolster And All Plastic Continuous High Chair

AR Plastic Slab Bolster is used for supporting lower slab steel from slab form. Corrugations spaced 1" (25 mm) on centres serve as guides for spacing bars. Legs are solid plastic 4" (100 mm) on centre. Supporting cross bar is made from high strength plastic coated steel. Corrosion-proof and lightweight for handling.

HEIGHT			
in	(mm)	in	(mm)
3/4	(20)	2 3/4	(70)
1	(25)	3	(76)
1 1/4	(32)	5	(125)
1 1/2	(38)	5 1/2	(138)
1 3/4	(44)	6	(150)
2	(50)	6 1/2	(163)
2 1/2	(63)	7	(175)

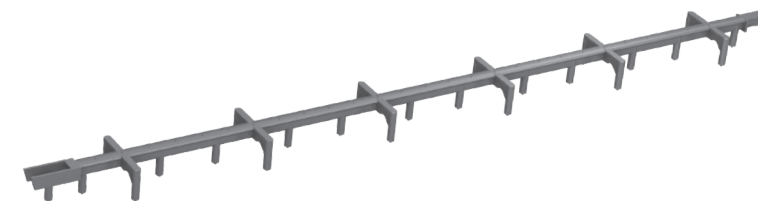

(CHC) Continuous High Chair

Continuous High Chairs provide support for upper slab steel from slab form, eliminating carrier bars required with individual supports. Fabricated with plain steel legs (CHC) or with plastic tipped legs (PCHC). Supplied To order in heights from 2" to 12" (50 mm to 300 mm) in 1/4" (5 mm) increments and in 5' (1525 mm) lengths with legs spaced at 6" (150 mm) o.c.



Tie Wire



- 50 lbs. Coils
- 3.5 lbs. Coils
- Wire Loop Tys
- Coated & Uncoated

Stencil Cutting Machine

The new Razor cutters are heavy-duty, durable cutters that hold material up to 60" wide with a maximum cutting width of 51.5". New Ethernet connection option allows you to print from multiple computers or workstations on your home or office network. With adjustable speed and cutting force which maxes out at 600g/65 IPS, this is the most powerful, versatile cutter you can buy. Razor cutters come with a three-year warranty (excludes shipping). Extended warranty options are available.

Stencil design and print services are also available, please contact your sales representative for more details.

Razor Series	Material Width	Max Cutting Width
724	30"	23.5"
740	48"	39.5"
752	60"	51.5"



Stencil Materials and Accessories

AR offers a variety of stencil cutting materials available in rolls of 6"-30" widths and 10'-300' lengths (material dependent). Replacement accessories such as rollers, cutting strips, application fluids and other parts are available to service your cutter, please contact your sales representative for more details.

- Clear Cut 5B
- Clear Cut 7B
- Clear Transfer Tape
- Electronic Cuttable Film
- Mag-Cut
- Magnetic Vinyl
- Opaque Transfer Tape
- Poly-Cut
- Poly-Cut SC
- Poly-HT
- Pro-Colour Vinyl
- Reflective Vinyl
- SSB
- Ultra-Colour
- Ultra-Cut II
- Vmask

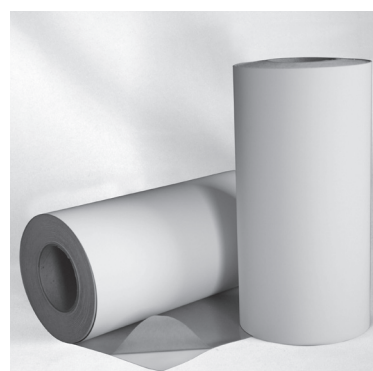

Linden Chairs

Corrosion free All Plastic Linden Chairs are used in slabs for supporting all types of reinforcing steel. Excellent for supporting epoxy coated rebar in bridge deck construction, or where-ever a corrosion free support is required. The high sizes have an arch design for straddling lower mats of rebar. The chair is made of High Impact polypropylene and its design gives it the strength of steel. Linden chairs are strong yet light in weight and packaged in poly bags for convenience of carrying around job sites.

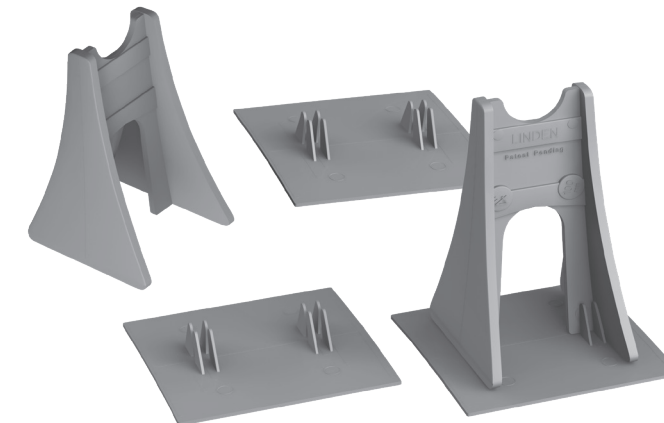

LINDEN CHAIRS SIZES AND PACKAGING WEIGHTS

inch	mm	PCS/BAG	LBS/MFT	CTN SKID	SKID QTY
1	25	500	30	40	20,000
1 1/4	32	500	35	40	20,000
1 1/2	40	250	46	40	10,000
1 3/4	45	250	50	40	10,000
2	50	250	62	40	10,000
2 1/4	58	200	78	40	10,000
2 1/2	63	200	82	40	8,000
2 3/4	70	300	84	25	7,500
3	75	300	85	25	7,500
3 1/4	77	300	88	25	7,500
3 1/2	85	300	90	25	7,500
3 3/4	92	200	93	25	5,000
4	100	200	95	25	5,000
4 1/4	108	200	98	25	5,000
4 1/2	110	200	112	25	5,000
4 3/4	120	200	119	25	5,000
5	125	200	120	25	5,000
5 1/4	133	200	125	25	5,000
5 1/2	140	200	130	25	5,000
5 3/4	146	200	148	25	5,000
6	150	100	155	25	2,500
6 1/4	158	100	160	25	2,500
6 1/2	165	100	177	25	2,500
6 3/4	170	100	184	25	2,500
7	175	100	195	25	2,500
7 1/4	183	75	255	25	1,875
7 1/2	190	75	310	25	1,875
7 3/4	195	75	338	25	1,875
8	200	75	343	25	1,875
8 1/4	210	75	350	25	1,875
8 1/2	215	50	365	25	1,250
8 3/4	220	50	378	25	1,250
9	228	50	400	25	1,250
9 1/4	235	50	415	25	1,250
9 1/2	240	50	424	25	1,250
9 3/4	247	50	430	25	1,250
10	254	50	440	25	1,250

LINDEN CHAIR DATA SHEET

Size Available	1-10 inches (25-254 mm) every 1/4" (6 mm)
Colour	concrete grey
Material	reinforced, high impact polypropylene
Strength	a minimum 400 lbs. (180 kg) / chair
Chemical Resistancy	excellent
Packaging	in heavy-duty uv protected poly bags Quantity varies by size
Installation	good for both Black and Corrosion resistant rebar place chairs on deck forms can straddle bottom steel bars spacing depends on loads standard spacing is every 3-4 feet (0.9 - 1.2 m)

Plastic Clip on Chairs

Plastic Clip on Chairs are used for supporting wide spaced light reinforcing steel in slab construction. Simply snaps on, no wiring necessary. Can be used in horizontal or vertical applications. Ideal for precast or prestressed. Made from polyethylene. Totally inert.

REINFORCING ROD SPACES SIZES

MODEL	SPACE/COVER inch (mm)	ROD SIZE RANGE inch (mm)
75-3/16	3/4 (20 mm)	3/16 - 1/4 (4 mm-6 mm)
75-1	3/4 (20 mm)	3/8 - 1/2 (9 mm-12 mm)
75-2	3/4 (20 mm)	5/8 - 1 (15 mm-25 mm)
100-3/16	1 (25 mm)	3/16 - 1/4 (4 mm-6 mm)
100-1	1 (25 mm)	3/8 - 1/2 (9 mm-12 mm)
100-2	1 (25 mm)	5/8 - 1 (15 mm-20 mm)
150-1	1 1/2 (40 mm)	3/16 - 1/4 (4 mm-6 mm)
150-2	1 1/2 (40 mm)	3/8 - 1/2 (9 mm-12 mm)
150-3	1 1/2 (40 mm)	5/8 - 7/8 (15 mm-22 mm)
150-4	1 1/2 (40 mm)	1 - 1 1/4 (25 mm-30 mm)
200-1	2 (50 mm)	3/16 - 1/4 (4 mm-6 mm)
200-2	2 (50 mm)	3/8 - 1/2 (9 mm-12 mm)
200-3	2 (50 mm)	5/8 - 7/8 (15 mm-22 mm)
200-4	2 (50 mm)	1 - 1 1/4 (25 mm-30 mm)

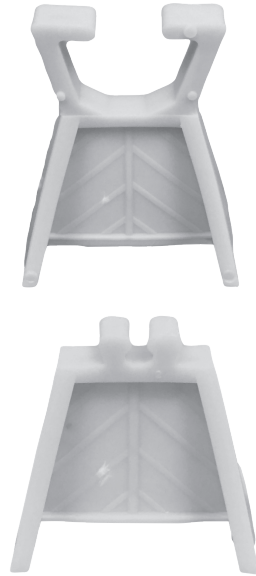

Reinforcing Bar X-Chair

The AR X-Chair is designed to support reinforcing rebar. It is made of a strong and durable plastic and is able to keep its shape even in the harsh Canadian climate. These chairs feature round nibs on each side of the legs and for easy and quick placement.

HEIGHT	
in	(mm)
1/2	(13)
3/4	(20)
1	(25)
1 1/2	(38)

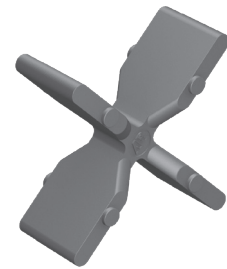

Precast Chair

The AR Precast Chair is a versatile stackable chair with a clip that fits mesh to 20M bar. It is made with composite material for strength, corrosion resistance and durability, while the design allows for concrete flow, eliminating the risk of voids. Its pointy legs result in minimal contact and exposure on the panel surface.

PART#	CHAIR HEIGHT		QTY/BAG
SC100	1.00"	25 mm	500
SC125	1.25"	32 mm	500
SC150	1.5"	40 mm	250
SC175	1.75"	45 mm	250
SC200	2.00"	50 mm	250
SC225	2.25"	58 mm	200
SC250	2.50"	63 mm	200
SC275	2.75"	70 mm	300
SC300	3.00"	75 mm	300
SC325	3.25"	77 mm	300
SC350	3.50"	85 mm	300
SC375	3.75"	92 mm	200
SC400	4.00"	100 mm	200

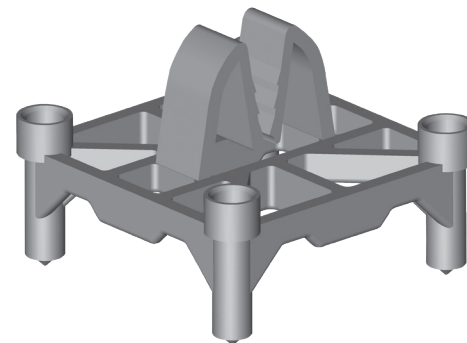

Smooth Edge Wagon Wheel

Circular Chairs Clip on Type Commonly known as "WAGON WHEELS". These versatile chairs are ideal for vertical bar supports in walls, beams or columns. Wagon wheels simply snap on to vertical bars, keeping forms and tubes a constant distance from steel. Made from solid polyethylene.



SMOOTH EDGE WAGON WHEEL DATA SHEET

Size Available	1", 1 1/2", 2" (25 mm, 38 mm, 50 mm)
Colour	natural
Material	strong, flexible polyethylene
Chemical Resistance	excellent
Packaging	in heavy-duty uv protected poly bags
Installation	snap opening onto either stirrups or vertical or horizontal bars

Bar No.	Cover (in)	Cover (mm)	Qty/Pack	Pack Weight (Lbs)	Pack Weight (Kg)
#4	1"	25	800	19	8.6
#5	1"	25	600	20	9.01
#4	1-1/2"	40	400	24	10.8
#5	1-1/2"	40	250	35	15.8
#5	1-1/8"	28	500	40	18.1
#5	2"	50	200	54	24.5

Ribbed Edge Wagon Wheel

General purpose circular spacer accommodates larger range of bar diameter. Heavy duty design easily supports extra loads.

Bar No.	Cover (in)	Cover (mm)	Qty/Pack	Pack Weight (Lbs)	Pack Weight (Kg)
#2-4	3/4"	19	2000	32	14.5
#5	1"	25	1000	21	9.5
#3	1-1/2"	40	500	22	10.0
#2	2"	50	250	15	6.8
#4-6	2"	50	250	16	7.3
#3-5	3"	75	100	9.7	4.4
#6	3"	75	100	10.5	4.8
#6-9	3"	75	100	15	6.8



Spun Cast Wheel

Non-slotted wheels for manufacturing spun cast concrete products. Rebar will not "unclip" from wheel during the spinning process.

WNS 10	GREY	10 m Bar	1 1/8" cover
WNS 10	BLACK	10 m Bar	1 1/8" cover
WNS 10	GREEN	10 m Bar	1 1/8" cover

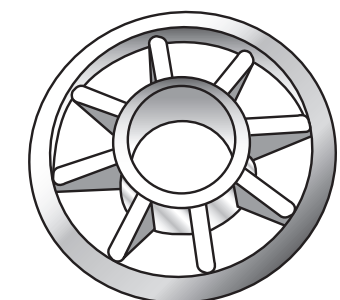

Stack Hi-Chairs

Heavy duty, stackable, rebar support system for a variety of cover requirements.

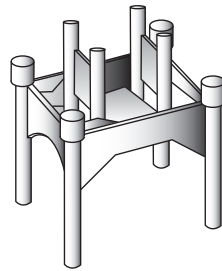

Code	Concrete Cover (in)	BarNo	Qty./Ctn.	lbs./Ctn.
HIC15	1 1/2"	All	250	32
HIC20	2"	All	250	21
HIC25	2 1/2"	All	250	22
HIC30	3"	All	200	15
HIC35	3 1/2"	All	200	16
HIC40	4"	All	200	10.5

EA Chair

Designed for exposed aggregate or sand-blasted concrete. Fine points at leg base make it virtually invisible on the surface of the architectural concrete.



Code	Concrete Cover (in)	BarNo	Qty./Ctn.	lbs./Ctn.
EAR10	1"	All	1000	15
EAR125	1 1/4"	All		
EAR15	1 1/2"	All	1000	20
EAR175	1 3/4"	All		
EAR20	2"	All	500	27
EAR25	2 1/2"	All	500	29
EAR30	3"	All	250	33
EAR35	3 1/2"	All	250	17
EAR40	4"	All	250	28

Recess Plug

For forming voids quickly and easily around ends of prestressed strands.

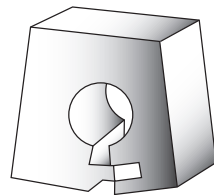

Prestress Sheathing

Designed to debond prestressed strand easily and economically.

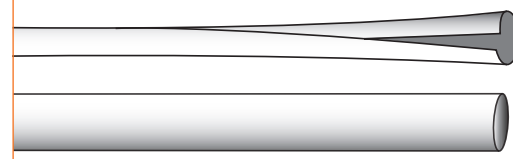

Chain Guards

AR Chain Guards are a versatile corner guard innovative product for securing precast products to ensure safe delivery. Loading and unloading product faster and simpler. Straps into the loading slots and tighten over the ridge of the corner guard. Internal ribbing will allow for secure, non-slip surface contact with your precast products.



Plastic Installation Accessories

"NO RUST PROBLEMS" AR plastic shimms are made from high impact polypropylene and are ideal for shimming during installations of equipment, etc. available in the following styles and sizes:

Horse Shoe Shims



SIZE		SIZE	
in	(mm)	in	(mm)
1/16 x 3 x 4	(1.6 x 76 x 100)	1/16 x 3 x 6	(1.6 x 76 x 150)
1/8 x 3 x 4	(3 x 76 x 100)	1/8 x 3 x 6	(3 x 76 x 150)
1/4 x 3 x 4	(6.35 x 76 x 100)	1/4 x 3 x 6	(6.35 x 76 x 150)
1/2 x 3 x 4	(13 x 76 x 100)	1/2 x 3 x 6	(13 x 76 x 150)

Also available in various sizes

Econo Shims

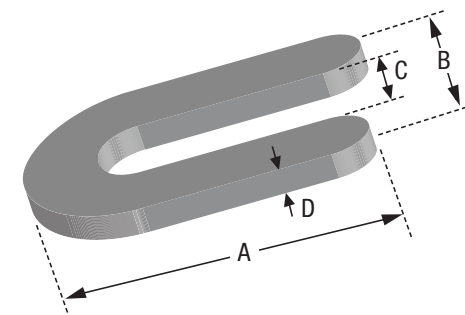

Length A	Width B	Slot C	Thickness D	Colour
2"	1 1/2"	1/2"	1/16"	Blue N#16
			1/8"	Red N#18
			1/4"	Black N#14
3"	2 5/16"	13/16"	1/16"	Blue N#26
			1/8"	Red N#28
			1/4"	Black N#24
3 1/2"	1 1/2"	1/2"	1/16"	Blue N#36
			1/8"	Red N#38
			1/4"	Black N#34
4"	3"	1/2"	13/16"	Blue N#56
			13/16"	Red N#58
			13/16"	Black N#54

Fluted Plastic Shims



SIZE	
in	(mm)
2 x 4 x 1/8 thick	(50 x 100 x 3 thick)
2 x 4 x 3/16 thick	(50 x 100 x 5 thick)
2 x 4 x 1/4 thick	(50 x 100 x 7 thick)
2 x 4 x 3/8 thick	(50 x 100 x 10 thick)

Plain Economy Plastic Shims (EPPS)

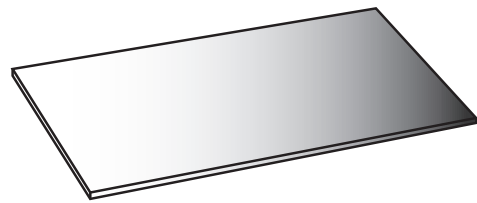

EPPS	SIZE	
	in	(mm)
1.5	2 x 4 x 1/16 thick	(50 x 100 x 1.5 thick)
3.5	2 x 4 x 1/8 thick	(50 x 100 x 3.0 thick)
7.0	2 x 4 x 1/4 thick	(50 x 100 x 7.0 thick)
13.0	2 x 4 x 1/2 thick	(50 x 100 x 13 thick)

Expanded Mesh

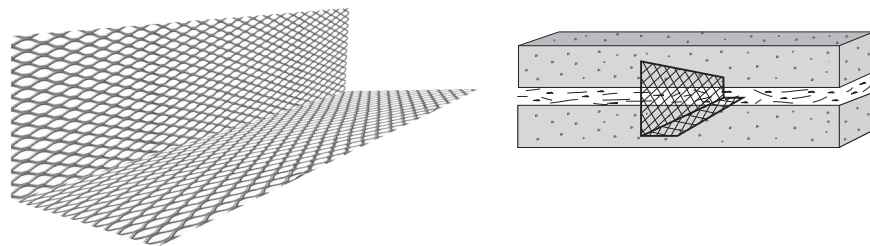

SIZE	
in	(mm)
1 3/4 x 5 x 24	(45 x 125 x 600)

Form Sealant



Rapid curing one component and Silicone Sealant design for sealing forms.

- Prevents Grout Leakage
- Unaffected by Foam Oils and Retarder
- Durable
- Excellent Adhesive
- May Replace Chamfer
- Leaves Smooth finish on Concrete Surface



Chamfers

PVC Chamfers have gained popularity in precast over traditional wood chamfers due to several benefits. Non-stick PVC Chamfers have a patented flexible edge seal, creating a tight seal against the casting surface which prevents concrete seepage, resulting in sharp, crisp lines and better overall finish. The higher cost upfront compared to caulking is quickly offset by eliminating the need to clean and scrape caulking/glue off forms and steel beds, saving time and labour. Installation times are therefore reduced, allowing for increased productivity.

Chamfer Strips

AR Chamfer Strips create architectural reveal and can be used to eliminate horizontal seams on form liner applications. Chamfer strips come in standard 10" (3,000 mm) lengths and can reused up to ten times. No rubbing, stoning, finishing or form release required.

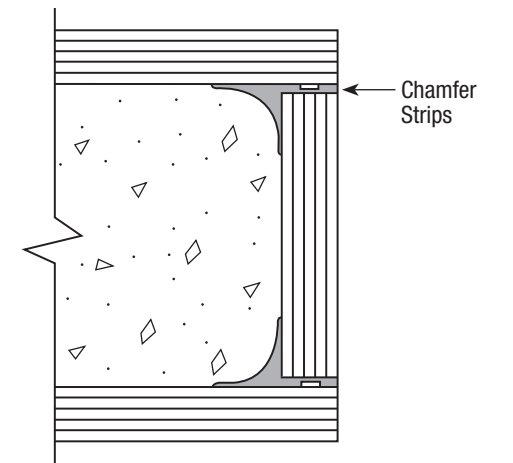
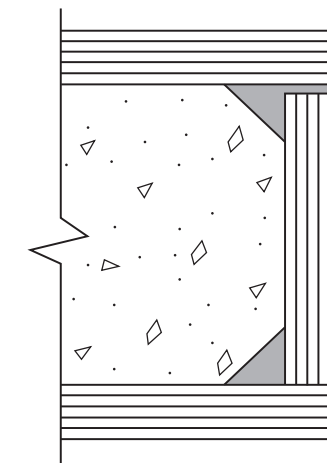
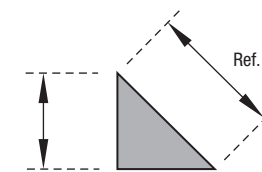
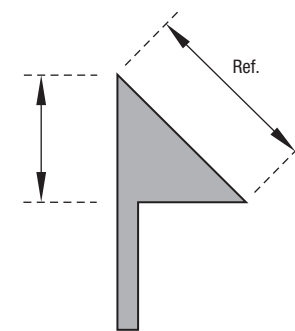
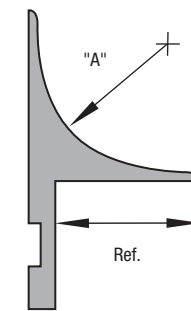

Chamfer Types	"A"		Ref.	
	in	mm	in	mm
Radius with Tail	1/2	(13)	3/8	(10)
	3/4	(20)	9/16	(15)
	1	(25)	3/4	(20)
Triangular with Tail	1/2	(13)	23/32	(18)
	3/4	(20)	1 1/16	(27)
	1	(25)	1 13/32	(36)
Triangular	1 1/2	(38)	2 1/8	(43)
	1/2	(13)	23/32	(18)
	3/4	(20)	1 1/16	(27)
	1	(25)	1 13/32	(36)

PVC - Chamfer Strips - Architectural Reveal Series

Style Number	Product Name	Width A	Height B	Width C	Chamfer Angle
902	1.0 x .75 x .75 Taped Reveal	1"	0.75"	0.75"	80°
878	.75 x .75 x .5 Taped Reveal	0.75"	0.75"	0.5"	81°
879	1 x 1 x .75 Taped Reveal	1"	1"	0.75"	83°

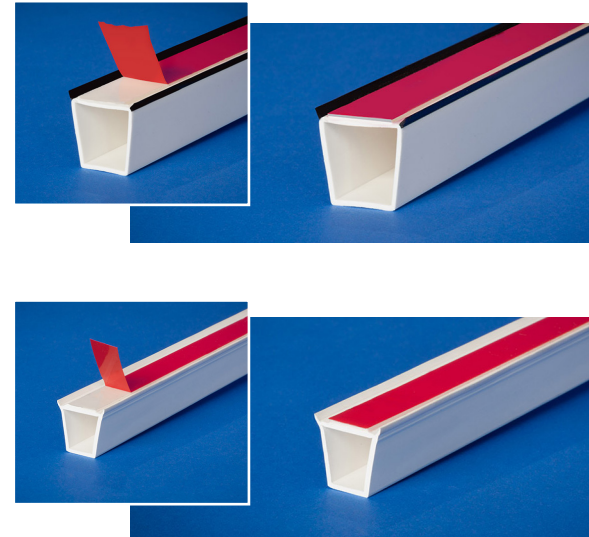
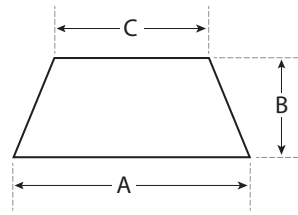
PVC - Chamfer Strips - Rustication

Product Name	Width A	Height B	Width C	Chamfer Angle
1.5 X .75 Tri-Snap Rustication	1.5"	0.75"	N/A	45°
2.0 Rustication*	2"	0.5"	1"	45°
2.25 Rustication*	2.25"	0.75"	0.75"	45°
2.5 Rustication*	2.5"	0.75"	0.9375"	45°
3.5 Rustication*	3.5"	0.75"	2"	45°
4.0 Rustication*	4"	0.75"	2.5"	45°
5.5 Rustication*	5.5"	0.75"	4"	45°

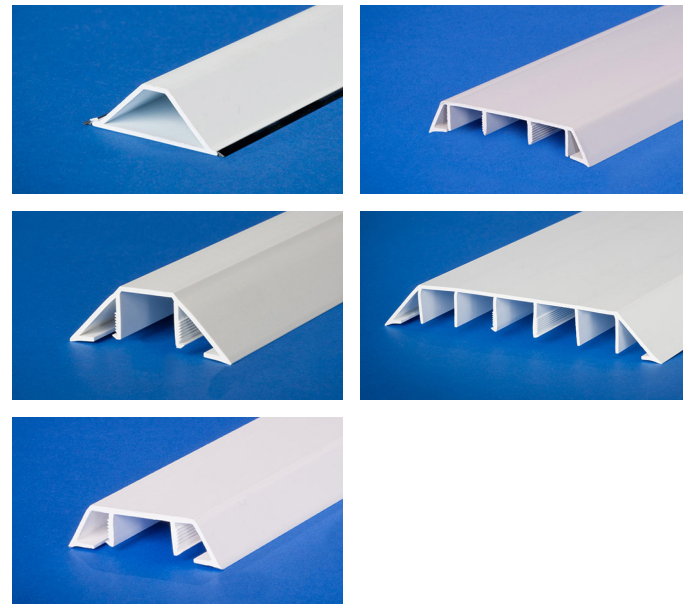
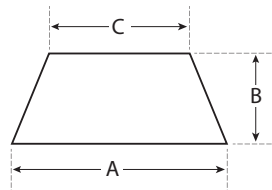
PVC - Single Chamfer

Product Name	Width A	Height B	Chamfer Angle
Snap Single Chamfer 3/4" With Tape	0.75"	0.75"	45°
LC Single Chamfer 3/4" With Tape	0.5"	0.75"	45°
LC Single Chamfer 1/2" With Tape	0.5"	0.5"	45°
Single Chamfer 3/4" Top / Inside Chamfer	0.75"	0.75"	45°
Single Chamfer 1/2" x 45 Degree	0.5"	0.5"	45°
LC Single Chamfer 1" With Tape	1"	1"	45°

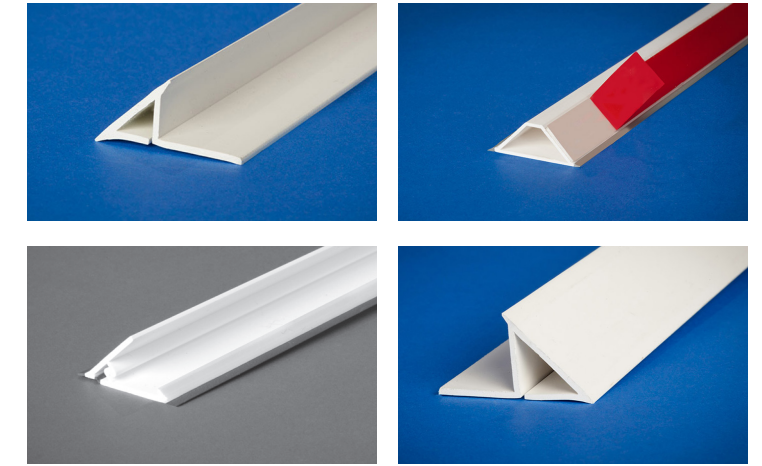
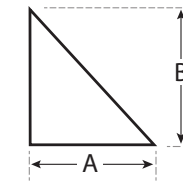
PVC - Double Chamfer

Product Name	Width A	Height B	Width C	Chamfer Angle
Double Chamfer 2 X 3/4	0.75"	0.75"	1.5"	45°

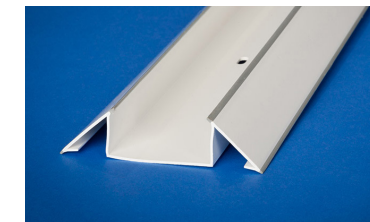
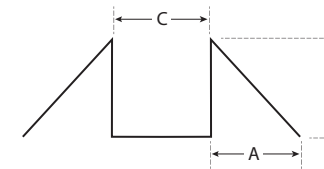
PVC - Concrete Accessories

Base Clip

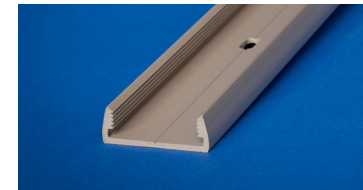

Magnet for Base Clip

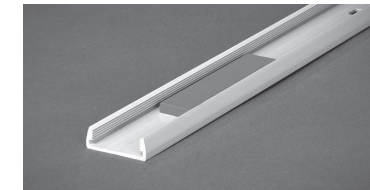

Universal Drip Edge Chamfer with Tape (1/2" Half-Round)

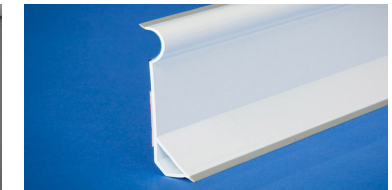

Joint Cover



Solid Architectural Drip Edge with Tape (3/8" Half-Round)



Saw Cut Cover

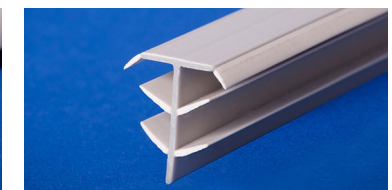

Dovetail Brick Anchors

AR Dovetail Brick Anchors 4 1/2", 5 1/2" & 6 1/2" (115 mm, 140 mm & 165 mm) long are made of 16 gauge (1.61 mm) galvanized sheet metal. Other lengths are available upon request. Also manufactured in non-ferrous material.

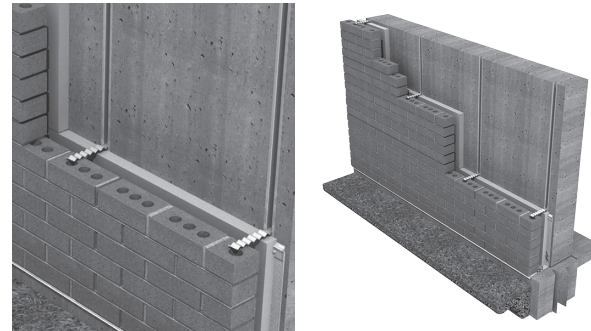
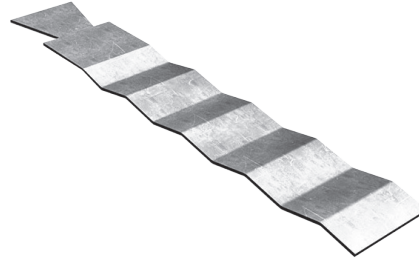

Dovetail Anchor Slot

AR's Dovetail Anchor Slot furnished with styrofoam filler eliminates the concrete from seeping into the anchor slot. Manufactured from 26 gauge (.55 mm) galvanized metal, in 8' (2.5 m) lengths.

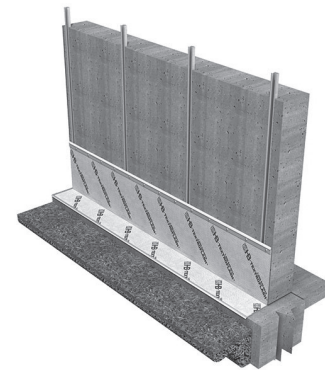
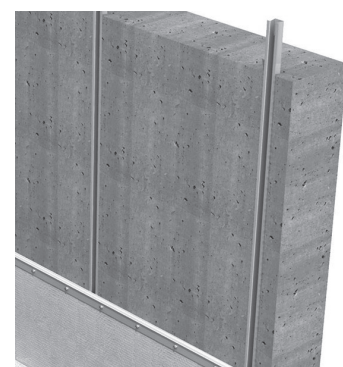
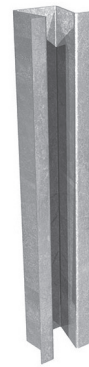

Fasteners



- Zinc Plated
- HDG
- 303 Stainless
- 316 Stainless

Form Liners

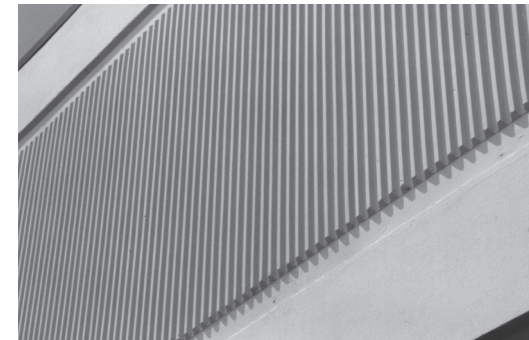

- Urethane
- ABS
- Hips

Formwork Pry Bar

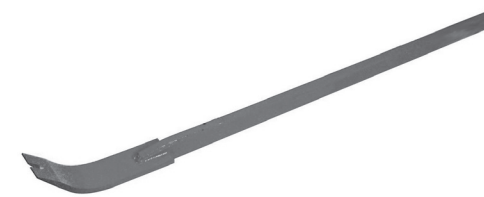

- Heavy Duty
- Tilt-up Erectors
- Assist in Removing Forms
- 3" Blade Widths

Reglet

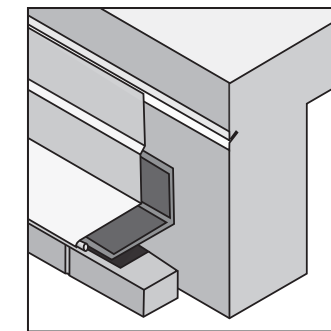
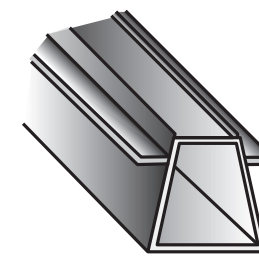

Sill Gaskets / Ethafoam

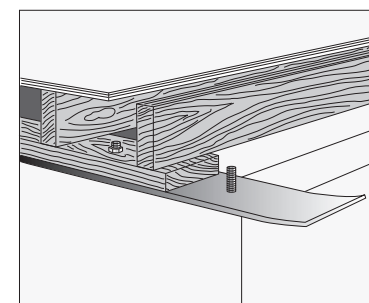

- Moisture Transfer Barrier
- Available in Different Widths and Thickness

Safety Products



- Caution Tape
- Hard Hats
- Safety Vest
- Fall Arrest
- Rebar Caps



CHEMICALS

Rich-Cote Form Release - W.B. - Summer Grade

AR water-based Rich-Cote is a premium liquid debonding agent developed especially for concrete. Through a chemical reaction, Rich-Cote produces a smooth white flat concrete surface which is free from voids and will bond with paint, plaster, tiles and any other coating applied directly to the concrete.



Rich-Cote Form Release - W.B. - Winter Grade

AR water-based Rich-Cote is a premium liquid debonding agent developed especially for concrete. Through a chemical reaction, Rich-Cote produces a smooth white flat concrete surface which is free from voids and will bond with paint, plaster, tiles and any other coating applied directly to the concrete. This special blend is specially formulated for cold temperatures.



Form Release Agents

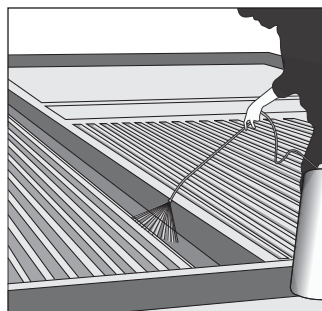

- Bond Breaker
- Water Based
- V.O.C

Premium High Gloss Acrylic Sealer

AR Premium High Gloss Sealer is a clear, ready-to-use formula of acrylic copolymers and quick evaporating solvents, which cures and/or seals freshly placed and/or existing concrete



Premium Acrylic Sealer

AR Premium Sealer is a clear, ready-to-use formula of acrylic copolymers and quick evaporating solvents, which cures and/or seals freshly placed and/or existing concrete. This blend is formulated with premium resins to provide a durable and lasting finish.



High Gloss Acrylic Sealer

AR High Gloss Sealer is a clear, ready-to-use formula of acrylic copolymers and quick evaporating solvents, which cures and/or seals freshly placed and/or existing concrete.



Acrylic Sealer

AR sealer is an economical curing and sealing compound formulated from acrylic polymers and quick-evaporating solvents. When applied on freshly placed concrete, it forms a clear, uniform, moisture-retentive film, which simultaneously cures and seals the concrete.

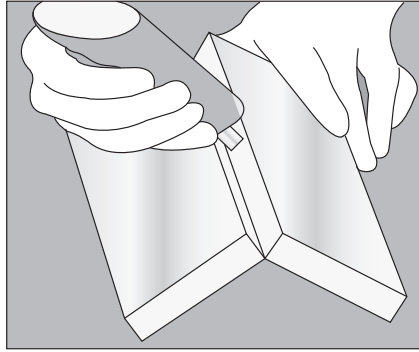

Adhesives

- White Glue
- Carpenter's Glue
- Waterproof Wood Glue
- Construction Adhesives

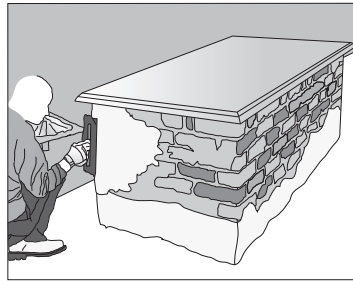
Bonding Agents

- Acrylic Latex
- Latex Emulsion
- Epoxy

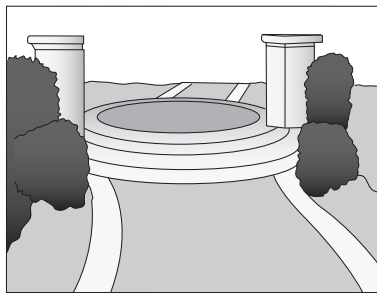
Colour Pigments

- Integral Colour
- Colour Hardeners
- Stains

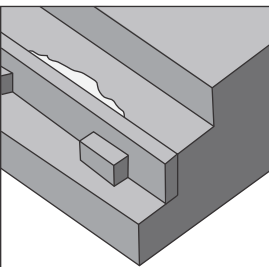
Patching Repair Products

- Polymer Modified
- Portland - White / Grey
- Portland High Early

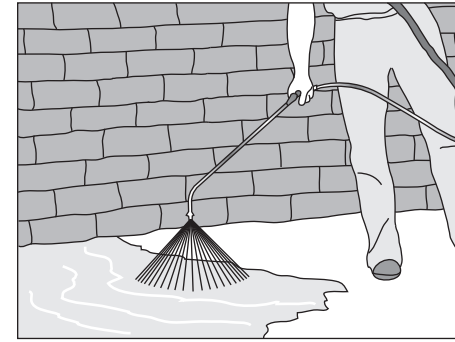
Concrete Curing Compounds

- White Curing Compound
- Clear Curing Compounds
- Water Based

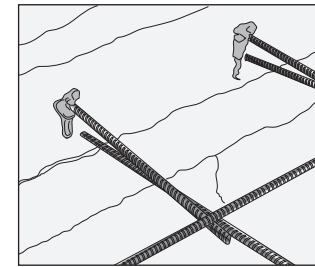
Epoxy Anchoring

- Hybrid Epoxy Acrylates
- Polyester
- Epoxy Adhesive
- Injectable Anchoring Gels

GENERAL INFORMATION

1. A qualified person must accurately calculate the applied loads and select the appropriate form tying products and determine compatible tie spacings.
2. In form tying operations, proper installation practices must be maintained. Failure to follow approved practices, such as missing form ties, misalignment of form ties, incorrect form tie lengths, excessive pour rates, etc., can cause form failure.
3. AR recommends the user of the information contained herein and the installer of our products adhere to the Canadian Standards Association CAN /CSA - S269.3 -M92 Concrete Formwork and American Concrete Institute -ACI 347 Guide to Formwork. The applied Approximate Safety Factor for a product will depend on the degree of hazard or risk involved in the product application. This Approximate Safety Factor is governed by National Codes, local codes and / or by design professionals. With regards to concrete construction, onsite conditions such as, poor concrete placing technique, concentrated loads on the formwork, improper use of cranes or concrete pumping could increase the degree of risk. If such site conditions exist, the user must increase the Approximate Safety Factor to compensate. For most applications AR suggests a minimum 2:1 Approximate Safety Factor for hanging accessories and stresses that this Approximate Safety Factor should be strictly adhered to or the application be reviewed by a design professional. The material included in this publication indicate the Approximate Safety Factor for convenience but also provides the ultimate capacities so other Approximate Safety Factors may be used where applicable. **WARNING : Improper, careless and/or haphazard use of the products shown in this document can expose workers to extreme danger, injury and death. If uncertain about installations or use of any AR product, contact the nearest AR Sales office or Technical Department for explanations and/or recommendations.** National Concrete Accessories products are manufactured according to strict specifications and are subject to numerous tests under a stringent quality control program. These products are designed to be capable of meeting or exceeding all necessary safety requirements for the concrete construction and forming industry. All product test data shown, were obtained through an independent testing facility or tests conducted by AR. However, the performance of a quality product can be affected by the manner in which it is used in the field. Therefore, the following precautions should be taken by all involved persons.
4. To avoid crushed wales and/or bent Tyholders when using a double waler system, maintain a spacing between the walers comparable to the tie diameter being used plus 13 mm (1/2").
5. Any welding should be performed by a certified welder. Bending or welding of high tensile steel products should not be permitted. Welding of precast accessories can be dangerous and should not be. *Note: AR does not warrant any product that has been welded, altered or modified in any way after leaving an AR plant or warehouse. After final inspection of location and alignment, telltale devices should be installed in strategic places on the formwork to facilitate detection of formwork movement during concrete placement.* During concrete placement, the formwork should be continuously monitored by competent persons. These monitors should have a reasonable area of safety and a means of communicating problems or emergencies to the placement crew.
6. Never exceed listed product safe working loads. Note that all product load ratings shown in this bulletin are ratings for new or "as new" products only. Extreme caution must be exercised when using any product that is in other than new condition. Any reusable product that shows wear, misuse, overloading, corrosion or any other factor that would compromise its safe working load should be discarded.
7. Caution must be exercised when using washer devices to span double wales. Waler gaps are excessive when the washer device does not bear directly on the primary waler members.
8. AR products are not to be applied or installed until the user and/or the installer has a clear understanding of the information contained within the appropriate product publication. All contractors must instruct their employees in the appropriate use and installation of AR products. To avoid injury and possible form tie problems DO NOT CLIMB ON FORM TIES. Over-vibration or re-vibration will cause lower concrete to remain in a liquid state for an extended period of time. This can cause excessive lateral form pressure and possible form failure Plumbing of the form, after concrete placement, should not be attempted. It is virtually impossible to force a form back into position if it is misaligned or has bulged during concrete placement. Runways for moving equipment should be provided with struts or legs as required and be supported directly on the formwork or structural member. Formwork must be suitable to support such runways without intolerable deflection, vibration or lateral movement.
9. Do not interchange products supplied by other manufacturers with those supplied by AR. AR cannot guarantee that products supplied by others will be compatible and/or interchangeable with AR's quality concrete accessories.
10. Drawings and/or sketches shown in this bulletin are for illustrative purposes only. Check actual forming conditions for specific applications. Metric values listed are a soft conversion of imperial values.

GENERAL INFORMATION

PRODUCT SAFETY AND INSTALLATION

The Approximate Safe Working Loads included in this publication were established based on all items are new or "as new" condition. Inserts are installed correctly and embedded in sound concrete suited for the application so that the vertical axis of the insert is perpendicular to the lifting surface. Installed hardware shall have full bearing on the concrete surface. Caution must be taken to prevent side loading which will cause additional stresses. Attachment and erection bolt must be installed using the proper length and penetration to prevent hardware accessories from slippage or bending. Caution must be observed and loads not imposed until such time as the concrete strength has reached the specified strength required for the insert. Inserts must be properly situated in relation to the edge, corner and openings so as to achieve the full capacity of concrete shear cone. The tensile loads applied to the insert included both axial and transverse loads transferred to the hardware from crane cables. Impact wrenches are not to be used for pre cast elements. Welding may cause embrittlement and could result in sudden failure. A metallurgical engineer must approve the process prior to any welding is undertaken. AR will not warrantee any modification or alterations made to its products.

Approximate Safety Factor

The following chart is the suggested Approximate Safety Factors used by industry standard for the degree of risk for the application. For the precast industry, the degree of risk involved can increase because of the adhesion to the form, jerking movement, transportation over rough terrain or roads. Approximate Safety Factors should be increase to suit the conditions. The minimum Approximate Safety Factors as suggested by OSHA (Occupational Safety and Health Administration), ANSI (American National Standards Institute and the CPCI (Canadian Precast Prestress Concrete Institute) is as followed:

Approximate Safety Factor	INTENDED PRODUCT USE
2 to 1	Brace anchors
3 to 1	Permanent Connection
4 to 1	Insert Used for lifting and handling
5 to 1	Hardware used for lifting and handling

For Approximate Safety Factors requirement that are different than included in this publications, Safe working loads must be adjusted by the user. The following equation is used to increase or reduce the safe working load by the following: $SWL + \text{Publication Factor of Safety} = \text{New Safe Working Load Required Factor of Safety}$.

The information contained herein supersedes all previous versions printed prior to this edition and is based on data and knowledge considered true and accurate. AR reserves the right to update information without notice. Please read all statements, recommendations or suggestions in conjunction with AR's condition of sale which apply to all goods supplied by AR. No statement, recommendations or suggestions is intended for any use that would infringe any patent or copyright.

NOTE: For applications not specifically identified herein, approval in writing is required by the AR Technical Department for special applications and uses of AR products.



ACROW - RICHMOND
THE HIDDEN STRENGTH™
LA FORCE CACHÉE

Acrow Richmond specializes in manufacturing hardware and accessories for the concrete construction industry. With our in-house engineering departments and over 100,000 square feet dedicated to manufacturing, we produce high quality Canadian made products.

We manufacture a full line of:

- Concrete forming hardware products for a wide range of forming systems
- Preset Anchoring systems ranging from street signs to high mast light systems
- Precast products for forming, lifting and connecting
- Rock Bolts for reinforcing severe slopes and tunnels
- Bridge deck forming hardware

In addition to a full line of traditional configurations and sizes, we offer custom fabrication services to meet the most demanding specifications or creative designs. Our team of experts can work with your project drawings to provide cost effective solutions that meet your load demands.

AR strives to be your first and only call for all of your construction needs.

You can find Acrow-Richmond products on all National Concrete Accessories branches across Canada.

For catalogue updates go to:

www.nca.ca

Contact us at:

1-888-777-9272